

ARMY TM 9-1240-379-34 MARINE CORPS TM 04332A-34

SUPERSEDES COPIES DATED DECEMBER 1977 AND JUNE 1964

TECHNICAL MANUAL

DIRECT SUPPORT AND GENERAL SUPPORT MAINTENANCE MANUAL FOR TANK PERISCOPE:

M32 (1240-00-766-4287)
M32C (1240-00-762-9335)
M32E1 (1240-01-016-2272)
M32CE1 (1240-01-092-7910)

TROUBLESHOOTING (DIRECT SUPPORT)	Page 2-1
-------------------------------------	-------------

MAINTENANCE PROCEDURES (DIRECT SUPPORT)	Page 2-8
---	-------------

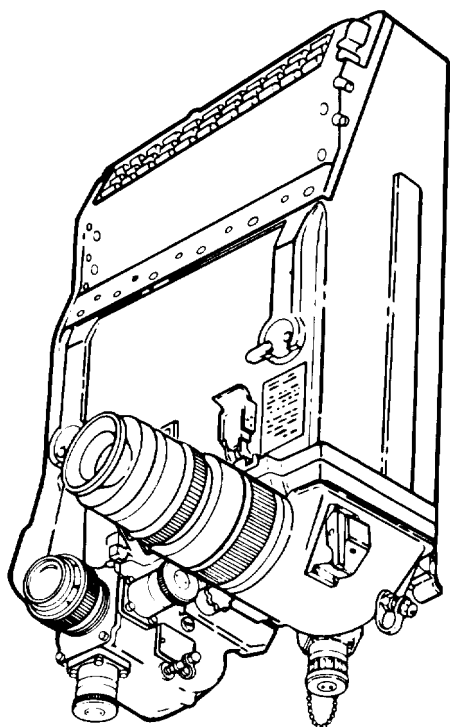

M32E1/M32CE1
TANK PERISCOPE

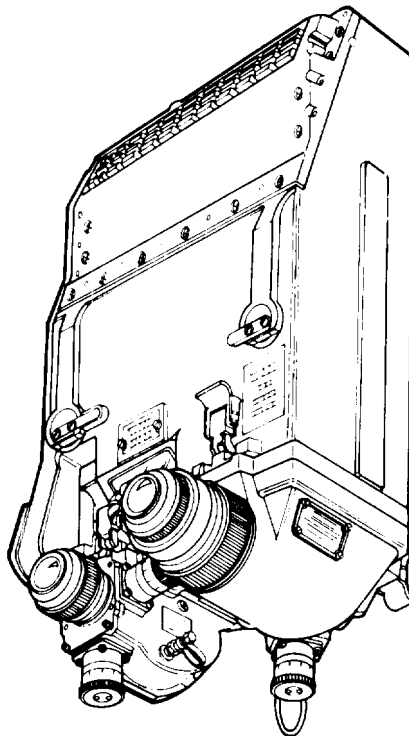

M32/M32C
TANK PERISCOPE

TROUBLESHOOTING (GENERAL SUPPORT)	Page 3-1
--------------------------------------	-------------

MAINTENANCE PROCEDURES (GENERAL SUPPORT)	Page 3 - 3
--	---------------

DISTRIBUTION STATEMENT A: Approved for public release; distribution is unlimited

HEADQUARTERS, DEPARTMENT OF THE ARMY
HEADQUARTERS, US MARINE CORPS

MAY 1988

WARNING

- Compressed nitrogen gas is used for purging and charging of equipment. Keep face and body clear of release valves. Death or severe injury may result if personnel fail to observe safety precautions. High pressure tanks can explode and kill people. Personnel shall be trained in the safe use, handling, and storage of compressed gases and gas cylinders.
- Various solvents and compounds which produce toxic vapors are used throughout this manual. Do not use toxic vapor producing agents in a confined area. Avoid long periods of breathing toxic vapors and avoid contact with the skin.
- Dry cleaning solvent is flammable and should not be used near an open flame or in a smoking area. Use only in well ventilated areas. This solvent evaporates quickly and has a drying effect on the skin. When used without gloves it may cause cracks in the skin and in some cases mild irritation or inflammation.
- When performing maintenance on the daylight body assembly, prism cell, and optical cell assembly be aware that detent plunger is under spring tension. Be careful when removing or injury may result.
- When performing maintenance on the head assembly, be careful when removing optical instrument window to avoid injury.
- For information on first aid, refer to FM 21-11.

TECHNICAL MANUAL

No. 9-1240-379-34
No. 04332A-34

HEADQUARTERS
DEPARTMENT OF THE ARMY
HEADQUARTERS
US MARINE CORPS
Washington, DC, 12 May 1988

Direct Support and General Support Maintenance Manual

For

TANK PERISCOPE:
M32 (1240-00-766-4287)
M32C (1240-00-762-9335)
M32E1 (1240-01-016-2272)
M32CE1 (1240-01-092-7910)

REPORTING ERRORS AND RECOMMENDING IMPROVEMENTS

You can help improve this manual. If you find any mistakes or if you know of a way to improve the procedures, please let us know. Mail your letter, or DA Form 2028 (Recommended Changes to Publications and Blank Forms), or DA Form 2028-2 located in the back of this manual direct to: Commander, US Army Armament, Munitions and Chemical Command, ATTN: AMSMC-MAS, Rock Island, IL 61299-6000. A reply will be furnished to you.

USMC users submit NAVMC Form 10772 direct to: Commanding General, Marine Corps Logistics Base (code 850), Albany, GA 31704-5000.

DISTRIBUTION STATEMENT A: Approved for public release; distribution is unlimited.

	Page
CHAPTER 1 INTRODUCTION	1-1
Section I General information	1-1
Section II Repair Parts, Special Tools, TMDE, and Support Equipment	1-2
Section III Equipment Description and Data	1-3
Section IV Principles of Operation	1-8
CHAPTER 2 DIRECT SUPPORT MAINTENANCE INSTRUCTIONS	2-1
Section I Troubleshooting	2-1
Section II Maintenance Procedures	2-8
Section III Preparation for Storage or Shipment	2-49
Section IV Pre-Embarkation Inspection of Materiel in Units Alerted for Overseas Movement	2-50

*This manual supersedes TM 9-1240-379-34, December 1977, and TM 9-1240-313-34, June 1964, including all changes.

	Page
CHAPTER 3 GENERAL SUPPORT MAINTENANCE INSTRUCTIONS	3-1
Section I Troubleshooting	3-1
Section II Maintenance Procedures	3-3
Section III Final Inspection	3-23
APPENDIX A REFERENCES	A-1
APPENDIX B EXPENDABLE/DURABLE SUPPLIES AND MATERIALS LIST	B-1
Section I Introduction	B-1
Section II Expendable/Durable Supplies and Materials List	B-2
APPENDIX C ILLUSTRATED LIST OF MANUFACTURED ITEMS	C-1
ALPHABETICAL INDEX	INDEX 1

CHAPTER 1 INTRODUCTION

Section I. GENERAL INFORMATION

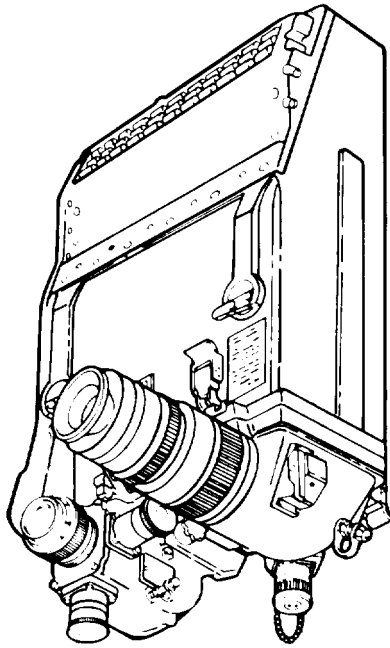

M32E1/M32CE1
TANK PERISCOPE

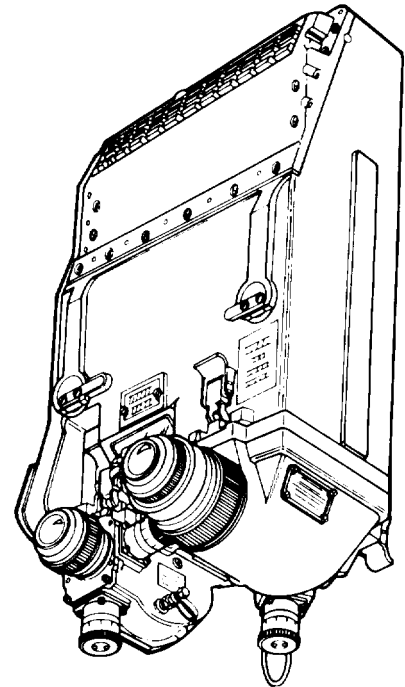

M32/M32C
TANK PERISCOPE

1-1. SCOPE.

a. **Type of Manual.** Direct support and general support maintenance.

b. **Model Number and Equipment Name.** M32, M32C, M32E1, and M32CE1 Tank Periscopes.

c. **Purpose of Equipment.** Provides a unity power system for wide, close-up vision of terrain and a visible 8X system for sighting distant targets.

1-2. MAINTENANCE FORMS, RECORDS, AND REPORTS.

Department of the Army forms and procedures used for equipment maintenance will be those prescribed by DA PAM 738-750, The Army Maintenance Management System

(TAMMS). USMC users will refer to TM 4700-15/1, Equipment Record Procedures.

1-3. DESTRUCTION OF ARMY MATERIEL TO PREVENT ENEMY USE.

Procedures and materials used for the destruction of the periscope to prevent enemy use will be found in TM 750-244-6.

1-4. PREPARATION FOR STORAGE OR SHIPMENT.

Requirements for storage or shipment are listed on page 2-49.

**1-5. OFFICIAL NOMENCLATURE,
 NAMES, AND DESIGNATIONS,**

This listing includes nomenclature references used in this manual.

COMMON NAME	OFFICIAL NOMENCLATURE
Cap assembly	Periscope subassembly
Deflection boresight knob assembly	Knob assembly
Elevation boresight knob assembly	Elevation knob assembly
Elevation boresight knob assembly	Boresighting knob assembly
Purging screw	Machine screw
RETICLE control knob	Knob
RETICLE variable resistor	Variable resistor
TUBE control knob	Knob
TUBE variable resistor	Variable resistor

1-6. REPORTING EQUIPMENT IMPROVEMENT RECOMMENDATIONS (EIR).

If your tank periscope needs improvement, let us know. Send us an EIR. You, the user, are the only one who can tell us what you don't like about your equipment. Let us

know why you don't like the design. Put it on an SF 368 (Quality Deficiency Report). Mail it to us at Commander, US Army Armament, Munitions and Chemical Command, ATTN: AMSMC-QAD, Rock Island, IL 61299-6000. We'll send you a reply. USMC users shall submit SF 368 in accordance with MCO 4855.10.

**Section II. REPAIR PARTS, SPECIAL TOOLS,
 TMDE, AND SUPPORT EQUIPMENT**

1-7. COMMON TOOLS AND EQUIPMENT.

For authorized common tools and equipment refer to the Modified Table of Organization and Equipment (MTOE) applicable to your unit.

1-8. SPECIAL TOOLS, TMDE, AND SUPPORT EQUIPMENT.

Refer to appendix C of this manual for manufacturing instructions for fabricated tools.

1-9. REPAIR PARTS.

Repair parts are listed and illustrated in the repair parts and special tools list (TM 9-1240-379-34P) covering direct support and general support maintenance for this equipment.

Section III. EQUIPMENT DESCRIPTION AND DATA

1-10. EQUIPMENT CHARACTERISTICS, CAPABILITIES, AND FEATURES.

a. M32 and M32C Tank Periscope Characteristics.

(1) Visible 8X system:

	US Customary	Metric Conversion
Magnification	8X	
Field of view	8°	
Effective focal length (EFL) of objective	8.813 in.	22.385 cm
Exit pupil diameter	0.200 in.	0.508 cm
Clear eye distance	0.63 in.	1.60 cm
Diopter (one)	0.031 in.	0.079 cm

(2) Unity power system:

Horizontal field of view	30°32'
Vertical field of view	5°48'

(3) Infrared 8X system:

Magnification	8X	
Field of view	8°	
EFL of objective	7.8 in.	19.8 cm
Image intensifier magnification	7.7 in.	19.6 cm
Clear eye distance	0.63 in.	1.60 cm
Diopter (one)	0.017 in.	0.043 cm

b. M32E1 and M32CE1 Tank Periscope Characteristics.

(1) Visible 8X system:

	US Customary	Metric Conversion
Magnification	8X	
Field of view	8°	
EFL of objective	8.813 in.	22.385 cm
Exit pupil diameter	0.200 in.	0.508 cm
Clear eye distance	0.63 in.	1.60 cm
Diopter (one)	0.031 in.	0.079 cm

(2) Passive 7.1 X system:

Magnification	7.1X	
Field of view	8°	
EFL of objective	7.8 in.	19.8 cm
EFL of eyepiece	1.100 in.	2.794 cm
Exit pupil diameter	0.059 in.	0.15 cm
Eye relief	0.850 in.	2.159 cm
Clear eye distance	0.600 in.	1.524 cm
Diopter (one)	0.031 in.	0.079 cm

1-10. EQUIPMENT CHARACTERISTICS, CAPABILITIES, AND FEATURES. (cont)

US Customary Metric Conversion

(3) Unity power system:

Horizontal field of view	30°32'
Vertical field of view	5°48'

c. Features. Each model of tank periscope consists of three separate and independent colimated units: head assembly, daylight body assembly, and infrared body assembly (night vision device for M32 and M32C) or elbow assembly (night vision device for M32E1 and M32CE1).

(1) The M32 and M32C tank periscopes contain a unity power system for wide, close-up vision of the terrain and a visible 8X system for sighting distant

targets. The visible 8X system is divided into one system for visible light observation of targets and an infrared system for night fighting targets.

(2) The M32E1 and M32CE1 tank periscopes have three optical systems consisting of a unity power system for wide, close-up vision of the terrain; a visible 8X system for visible daylight sighting of targets; and a passive 7.1X system for night sighting of targets.

1-11. LOCATION AND DESCRIPTION OF MAJOR COMPONENTS.

a. Head Assembly (1). Light-gathering instrument; serves as input source for daylight and night sighting systems. An internal mirror can be rotated from a depression of 18 degrees to an elevation of 22 degrees from the line of sight; rotation is limited to gun elevation capabilities.

b. Daylight Body Assembly (2). Installed in left opening of head assembly. Houses visible 8X system. Monocular unit consisting of etched reticle positioned by deflection and elevation boresight knob assemblies for gun laying, adjustable diopter eyepiece, and an incandescent lamp to illuminate the reticle.

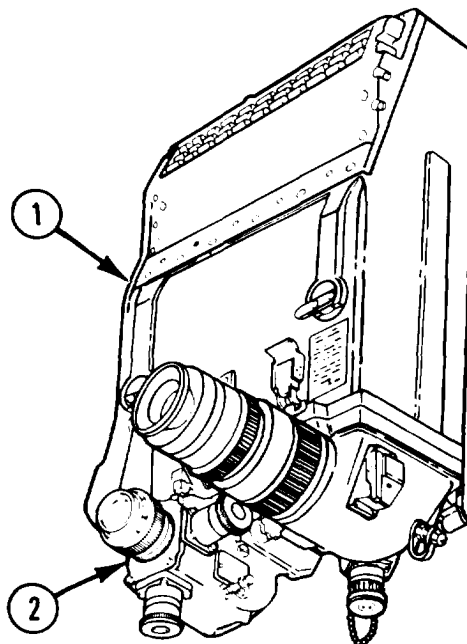

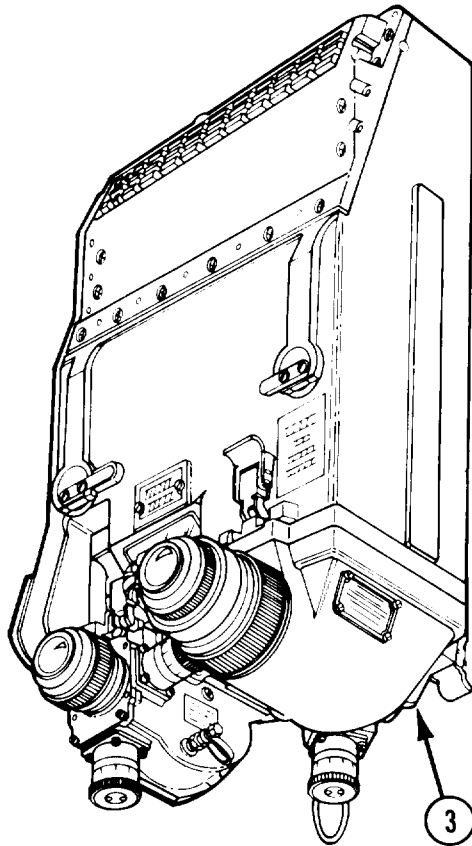

c. Infrared Body Assembly (3). Monocular type elbow telescope used for night sighting of targets. Has an integral reticle projection system positioned by deflection and elevation boresight knob assemblies. Power is supplied from the 24 V dc tank power system. A converter and a power pack is used to adjust the voltage to 16,000 volts for operation of the image intensifier. Short waves within the infrared spectrum produce an image by reflection of infrared light off an object.

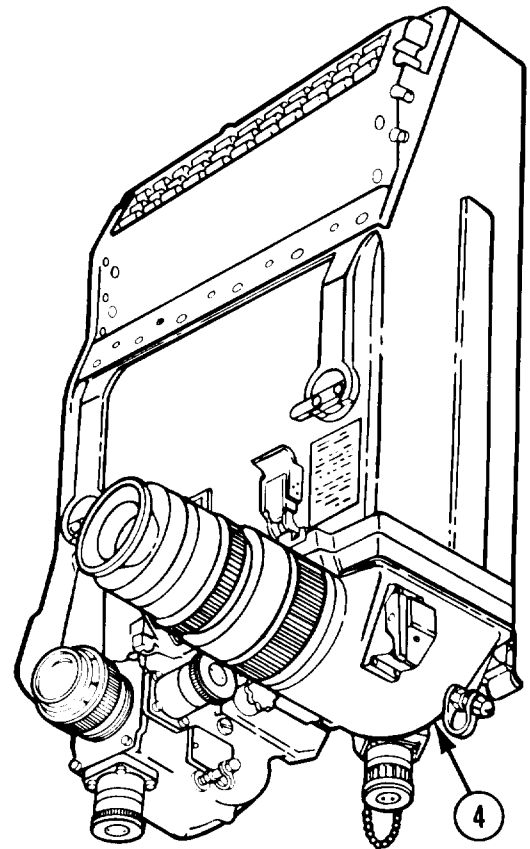

d. Elbow Assembly (4). Nighttime counterpart of the daylight body assembly. Amplifies available visible light by means of an image intensifier and solid power supply, making objects visible without the aid of a searchlight. Electrical power to energize the image intensifier is provided by either the 24 V dc tank power system or a 3.2 V dc M30 instrument light.

1-11. LOCATION AND DESCRIPTION OF MAJOR COMPONENTS. (cont)

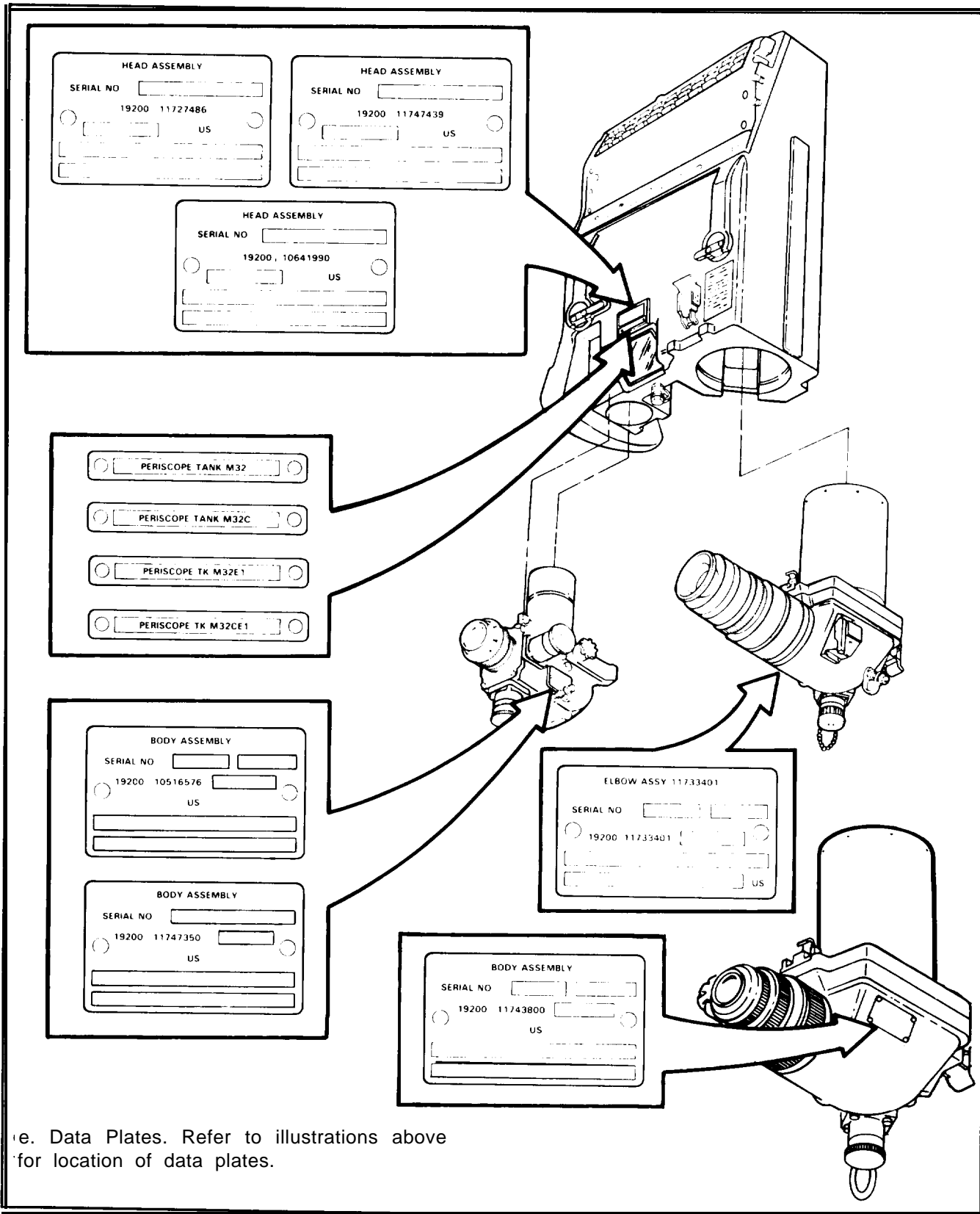

e. Data Plates. Refer to illustrations above for location of data plates.

1-12. DIFFERENCES BETWEEN MODELS.

The main difference between the four models of M32 series tank periscope is the night vision system.

a. M32 and M32C Tank Periscopes. Utilize an infrared body assembly. The system requires a 24 V dc power source to energize the solid power supply, providing electrical input to the converter regulator converting the output to 16,000 volts to the image intensifier and providing night sighting of targets. Emergency operation in event of power failure can be achieved by replacing

converter regulator with a 1.5 V C-size battery.

b. M32E1 and M32CE1 Tank Periscopes. Utilize an elbow assembly. The system requires a 24 V dc power source to converter regulator converting the voltage to the image intensifier to 2.35 V dc. Light intensity can be varied from low to high by adjustment of the RETICLE control knob and/or TUBE control knob. An electrical connector is provided to accommodate a 3.2 V dc M30 instrument light, if desired.

1-13. EQUIPMENT DATA.

a. M32 and M32C Tank Periscopes.

	US Customary	Metric Conversion
(1) Weight.		
Head assembly	25 lb	11.34 kg
Infrared body assembly	23 lb	10.43 kg
Daylight body assembly	5 lb	2.27 kg
(2) Dimensions.		
Height	20.5 in.	52.07 cm
Width	13.38 in.	33.99 cm
Depth	12 in.	30.48 cm

b. M32E1 and M32CE1 Tank Periscopes.

(1) Weight.		
Head assembly	25 lb	11.34 kg
Elbow assembly	24 lb	10.89 kg
Daylight body assembly	5 lb	2.27 kg
(2) Dimensions.		
Height	20.5 in.	52.07 cm
Width	13.5 in.	34.29 cm
Depth	12.62 in.	32.05 cm

1-14. SAFETY, CARE, AND HANDLING.

WARNING

The following safety precautions are listed for the protection of personnel performing maintenance procedures contained in this manual. Failure to follow prescribed precautions may result in injury to personnel.

- Compressed Gas. Compressed nitrogen gas is used for purging and charging of equipment. Keep face and body clear of release valves. Death or severe in-

jury may result if personnel fail to observe safety precautions. High pressure tanks can explode and kill people. Personnel shall be trained in the safe use, handling, and storage of compressed gases and gas cylinders.

- Toxic Vapors. Various solvents and compounds which produce toxic vapors are used throughout this manual. Do not use toxic vapor producing agents in a confined area. Avoid long periods of breathing toxic vapors and avoid contact with skin.

Section IV. PRINCIPLES OF OPERATION

1-15. OPERATING PRINCIPLES.

a. Refer to TM 9-2350-215-10-1 for operating principles for the tank periscope used on the M60A1 combat tank.

b. Refer to TM 9-2350-257-10-1 for operating principles for the tank periscope used on the M60A1 combat tank (rise and rise passive).

c. Refer to TM 9-2350-258-10 for operating principles for the tank periscope used on the M48A5 combat tank.

d. Refer to TM 9-2350-260-10-1 for operating principles for the tank periscope used on the M60 combat tank.

CHAPTER 2 DIRECT SUPPORT MAINTENANCE INSTRUCTIONS

Section I. TROUBLESHOOTING

2-1. TROUBLESHOOTING INFORMATION.

a. The symptom index can be used as a quick guide to troubleshooting. Common malfunctions are listed in alphabetical order with a page number reference to the troubleshooting table where a test or inspection and corrective action are provided.

manual cannot list all malfunctions that may occur, nor all tests or inspections and corrective actions. If the malfunction is not listed, or if the malfunction still exists after all listed corrective actions have been performed, notify general support maintenance.

b. Table 2-1 lists the malfunction, the test or inspection indicating the malfunction, and the corrective action needed. This

SYMPTOM INDEX

	Troubleshooting Procedure (Page No.)
DAYLIGHT BODY ASSEMBLY	
Poor vision through daylight body assembly	2-3
Poor or no illumination of reticle	2-2
ELBOW ASSEMBLY	
Poor vision through image intensifier elbow	2-6
No night channel image, low brilliance of night image, or night image flickers or moves.	2-6
Poor or no illumination of night reticle	2-5
INFRARED BODY ASSEMBLY	
Poor vision through infrared body assembly	2-5
Poor or no illumination of night reticle	2-3
TANK PERISCOPE (ALL MODELS)	
Loss of boresight	2-2

2-1. TROUBLESHOOTING INFORMATION. (cont)

Table 2-1. TROUBLESHOOTING

MALFUNCTION	TEST OR INSPECTION	CORRECTIVE ACTION
TANK PERISCOPE (ALL MODELS)		
1. LOSS OF BORESIGHT.		
Step 1. Make sure elevation and deflection knob assemblies are fully engaged with their positive clutches.		
If knob cannot be engaged, replace appropriate knob assembly. (Refer to page 2-16 for daylight body assembly; refer to page 2-27 for infrared body assembly; refer to page 2-39 for elbow assembly.)		
Step 2. Check that daylight body assembly, infrared body assembly or elbow assembly is properly seated.		
a. Check for foreign matter around locating pads. Clean as necessary. b. Check for damaged periscope latches or strikes. Replace authorized parts (page 2-16, 2-27, or 2-39) as necessary. c. If boresight capabilities are not restored, replace daylight body assembly, infrared body assembly, or elbow assembly (Page 2-8), as appropriate.		
DAYLIGHT BODY ASSEMBLY		
2. POOR OR NO ILLUMINATION OF RETICLE.		
Step 1. Check for damaged or defective incandescent lamp (page 2-16).		
Replace damaged or defective incandescent lamp (page 2-16).		

Table 2-1. TROUBLESHOOTING (cont)

MALFUNCTION	TEST OR INSPECTION	CORRECTIVE ACTION
	Step 2. Perform continuity check between contact and electrical ring. (Refer to page 2-16 for identification of parts.)	<ul style="list-style-type: none">a. Replace damaged or defective contact (page 2-16.)b. If malfunction is not corrected, replace daylight body assembly (page 2-8).
3. POOR VISION THROUGH DAYLIGHT BODY ASSEMBLY.		
	Step 1. Check for proper alinement of reticle. Adjust diopter length.	
	Step 2. Check for dirt or fingerprints on all exposed optical surfaces. Clean optics in accordance with TM 9-254.	
	Step 3. Check for condensation; if moisture is present, check for defective sealing or a defective valve core and purging valve stem using a soapy solution.	<ul style="list-style-type: none">a. Replace valve core (page 2-16) or purging valve stem (page 2-16), as necessary.b. Purge and charge in accordance with TM 750-116.c. If sealing is defective, replace daylight body assembly (page 2-8).
		INFRARED BODY ASSEMBLY
4. POOR OR NO ILLUMINATION OF NIGHT RETICLE.		
	Step 1. Check for damaged or defective incandescent lamp (page 2-27) Replace damaged or defective incandescent lamp (page 2-27).	
	Step 2. Check if electron tube reflects green grain image when rotary switch is turned on.	<ul style="list-style-type: none">a. Replace damaged or defective electron tube (page 2-27).

2-1. TROUBLESHOOTING INFORMATION. (cont)

Table 2-1. TROUBLESHOOTING (cont)

MALFUNCTION	TEST OR INSPECTION	CORRECTIVE ACTION
-------------	--------------------	-------------------

INFRARED BODY ASSEMBLY (cont)

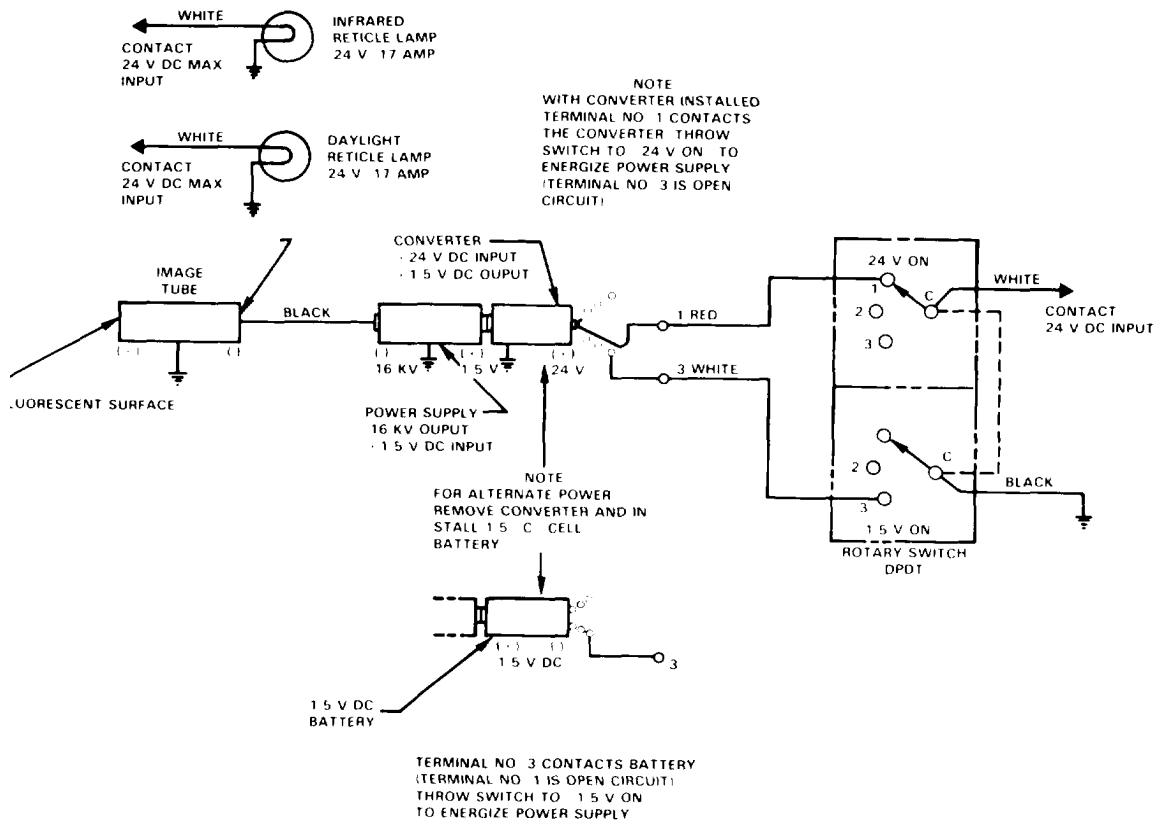

- b. If malfunction cannot be corrected, replace infrared body assembly (page 2-8).

Table 2-1. TROUBLESHOOTING (cont)

MALFUNCTION	TEST OR INSPECTION	CORRECTIVE ACTION
5. POOR VISION THROUGH INFRARED BODY ASSEMBLY.		
	Step 1. Check for proper alinement of reticle.	Adjust diopter length.
	Step 2. Check for dirt or fingerprints on all exposed optical surfaces.	Clean optics in accordance with TM 9-254.
	Step 3. Check for condensation; if moisture is present, check for defective sealing or a defective valve core and purging valve stem using a soapy solution.	a. Replace valve core (page 2-27) or purging valve stem (page 2-27), as necessary. b. Purge and charge in accordance with TM 750-116. c. If sealing is defective, replace infrared body assembly (page 2-8).
ELBOW ASSEMBLY		
6. POOR OR NO ILLUMINATION OF NIGHT RETICLE.		
	Step 1. Check that RETICLE control knob is properly adjusted.	
	Step 2. Check for damaged or defective incandescent lamp.	Replace incandescent lamp (page 2-39), as necessary.
	Step 3. With objective lens covered to simulate darkness, turn shutter assembly switch to 3 V ON position and operate TUBE control knob.	a. If image intensifier lights, notify next higher level of maintenance to replace RETICLE control knob. b. If image intensifier does not reflect a green grain image, notify next higher level of maintenance to replace regulator assembly. c. Replace elbow assembly (page 2-8), if required.

2-1. TROUBLESHOOTING INFORMATION. (cont)

Table 2-1. TROUBLESHOOTING (cont)

MALFUNCTION TEST OR INSPECTION	CORRECTIVE ACTION
7. POOR VISION THROUGH IMAGE INTENSIFIER ELBOW. Step 1. Check for proper alinement of reticle. Adjust diopter length. Step 2. Check for dirt or fingerprints on all exposed optical surfaces. Clean optics in accordance with TM 9-254. Step 3. Check for condensation; if moisture is present, check for defective sealing or a defective valve core and purging valve stem using a soapy solution.	a. Replace valve core (page 2-39) or purging valve stem (page 2-39), as necessary. b. Purge and charge in accordance with TM 750-116. c. If sealing is defective, replace elbow assembly (page 2-8).
8. NO NIGHT CHANNEL IMAGE, LOW BRILLIANCE OF NIGHT IMAGE, OR NIGHT IMAGE FLICKERS OR MOVES. Step 1. Check that shutter assembly switch is ON. Step 2. Check that TUBE control knob is properly adjusted to obtain sufficient image brightness. Step 3. Check that image intensifier is not defective.	Replace image intensifier if defective (page 2-39).

Table 2-1. TROUBLESHOOTING (cont)

MALFUNCTION	TEST OR INSPECTION	CORRECTIVE ACTION
<p>Step 4. Check continuity of TUBE potentiometer and resistor R1 (refer to wiring diagram).</p>		
<p>Replace elbow assembly (page 2-8), if necessary.</p>		

Section II. MAINTENANCE PROCEDURES

2-2. TANK PERISCOPE-MAINTENANCE INSTRUCTIONS.

THIS TASK COVERS:

- a. Disassembly b. Inspection/cleaning/repair c. Reassembly

INITIAL SETUP

Tools and Special Tools

Instrument and fire control shop equipment (SC 4931-95-CL-A07)
Instrument and fire control system repair shop equipment (SC 4931-95-CL-A09)

Lens paper (item 14, app B)

References

TM 9-254
TM 9-1240-379-34P
TM 750-116

Materials/Parts

Artist's brush (item 3, app B)
Ethyl alcohol (item 9, app B)

DISASSEMBLY

CAUTION

The light shield must be kept in place at all times when the infrared body assembly or elbow assembly is removed from the head assembly. Direct sunlight or high intensity artificial light can damage or destroy the electron tube or image intensifier.

NOTE

Infrared body assembly is used on M32 and M32C tank periscopes. Elbow assembly is used on M32E1 and M32CE1 tank periscopes. The elbow assembly is illustrated.

- 1 Support infrared body assembly or elbow assembly (1) with hand; release periscope latch (2) on infrared body assembly or elbow assembly (1) and periscope latch (3) on head assembly (4).
- 2 Carefully remove infrared body assembly or elbow assembly (1) from head assembly (4).

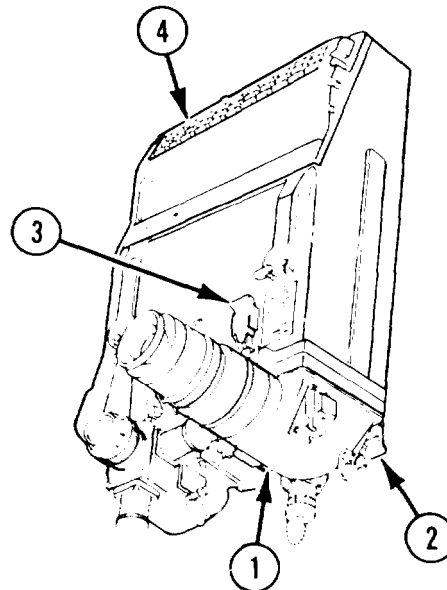

NOTE

There are two configurations of the daylight body assembly. Follow step 3 for the M32 or M32E1 tank periscope. Follow step 4 for the M32C or M32CE1 tank periscope.

- 3 Loosen two screws (5); support daylight body assembly (6) with hand and remove two screws (5) and two lockwashers (7). Carefully lower daylight body assembly (6) from head assembly (4).

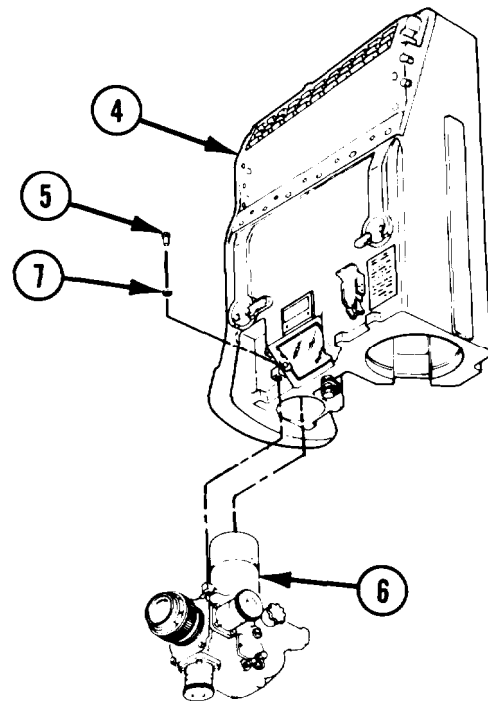

INSPECTION/CLEANING/REPAIR

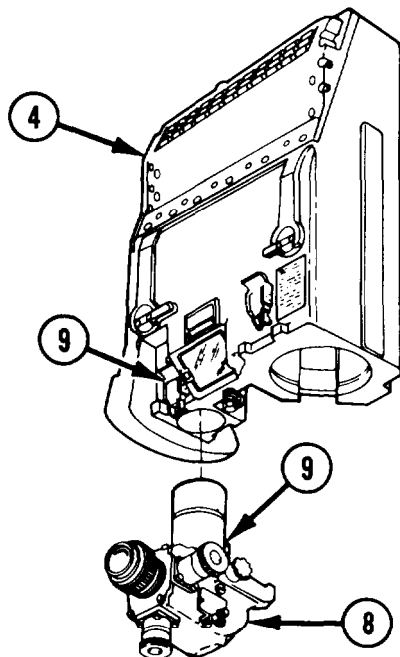

- 4 Support daylight body assembly (8) with hand and release two periscope latches (9); carefully remove daylight body assembly (8) from head assembly (4).

- 1 Replace any damaged, broken, or missing parts. See TM 9-1240-379-34P.
- 2 Clean optical surfaces in accordance with TM 9-254.

2-2. TANK PERISCOPE-MAINTENANCE INSTRUCTIONS. (cont)

REASSEMBLY

NOTE

There are two configurations of the daylight body assembly. Follow step 1 for the M32 or M32E1 tank periscope. Follow Step 2 for the M32C or M32CE1 tank periscope.

1. Position daylight body assembly (1) in head assembly (2); secure with two lockwashers (3) and two screws (4).

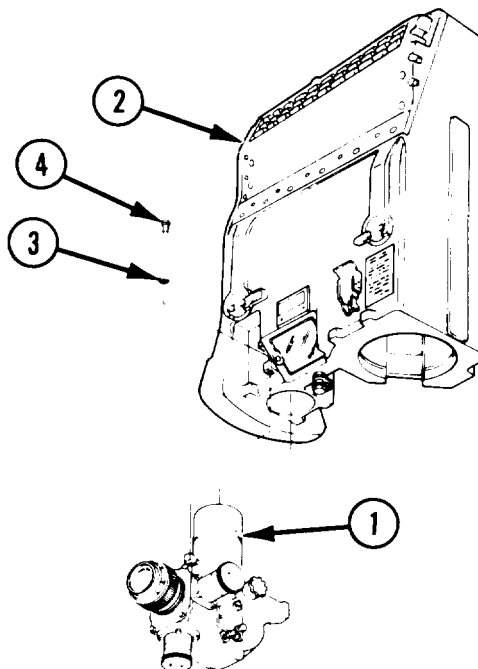

2. Position daylight body assembly (5) in head assembly (2) and latch two periscope latches (6).

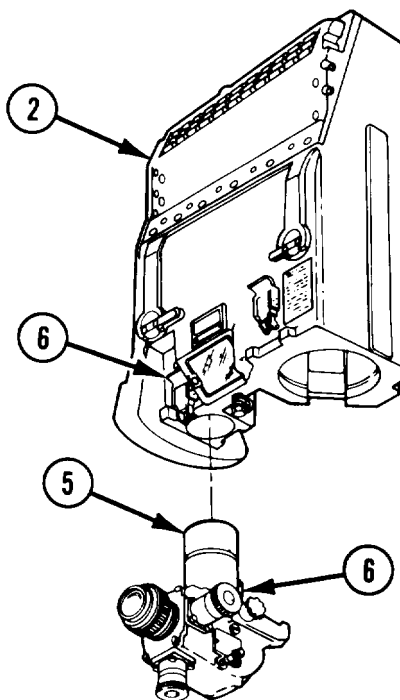

- 3 Carefully position infrared body assembly or elbow assembly (7) on head assembly (2).
- 4 Secure periscope latch (8) on head assembly (2) and periscope latch (9) on infrared body assembly or elbow assembly (7).
- 5 After maintenance has been completed, purge and charge in accordance with TM 750-116.

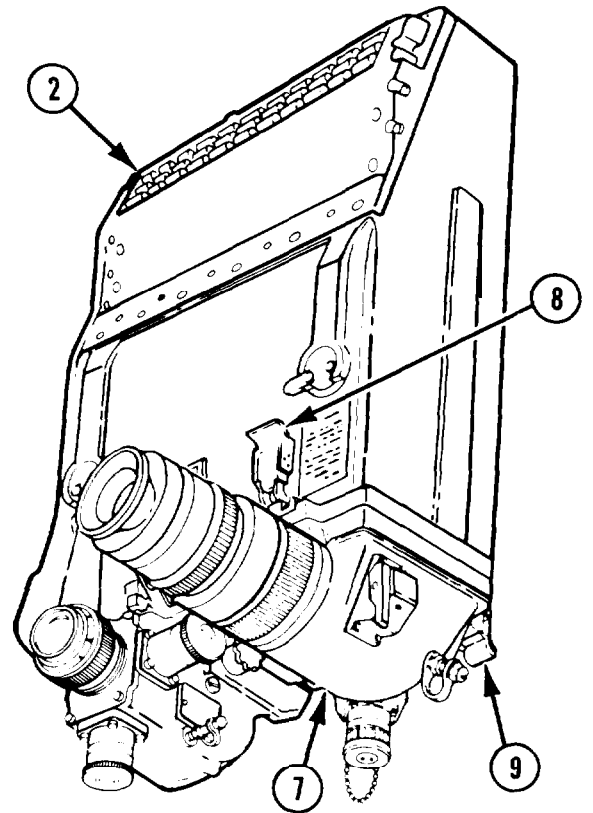

2-3. HEAD ASSEMBLY—MAINTENANCE INSTRUCTIONS.

THIS TASK COVERS:

- | | | |
|----------------|----------------------|---------------|
| a. Disassembly | b. Inspection/repair | c. Reassembly |
|----------------|----------------------|---------------|

INITIAL SETUP

Tools and Special Tools

- Instrument and fire control shop equipment (SC 4931-95-CL-A07)
- Instrument and fire control system repair shop equipment (SC 4931-95-CL-A09)

Materials/Parts

- Dry cleaning solvent (item 8, app B)
- Gloves (item 10, app B)
- Sealing compound (item 16, app B)

References

- TM 9-1240-379-34P
- TM 750-116

Equipment Conditions

- Page 2-8 Daylight body assembly and infrared body assembly or elbow assembly removed from head assembly

2-3. HEAD ASSEMBLY—MAINTENANCE INTRUCTIONS. (cont)

DISASSEMBLY

- 1 Loosen pneumatic valve cap (1) and remove from purging valve stem (2).
- 2 Loosen hexagon nut (3) and remove from purging valve stem (2).
- 3 Remove valve cap strap (4) from purging valve stem (2) and then from pneumatic valve cap (1).
- 4 Remove valve core (5) from purging valve stem (2).
- 5 Remove purging valve stem (2) from head assembly (6).

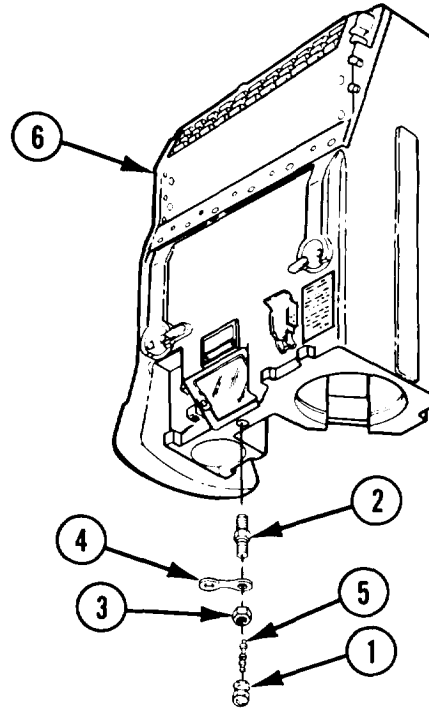

- 6 Remove two machine screws (7) and two lockwashers (8).
- 7 Remove periscope latch (9).

NOTE

Follow steps 8 and 9 for the M32 or M32E1 tank periscope. Follow steps 10 or 11 for the M32C or M32CE1 tank periscope.

- 8 Remove two socket capscrews (10) and two lockwashers (11).
- 9 Remove angle bracket (12).
- 10 Remove two machine screws (13) and two lockwashers (14).
- 11 Remove periscope latch (15).

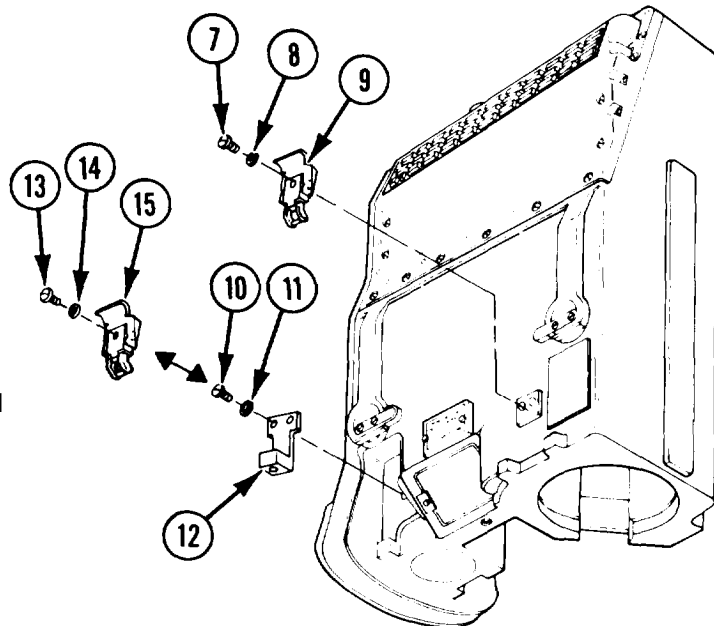

12 Remove two machine screws (16) and two lockwashers (17).

13 Remove strike (18).

NOTE

Follow steps 14 and 15 for the M32C or M32CE1 tank periscope. Follow steps 16 and 17 for the M32 or M32E1 tank periscope.

14 Remove two machine screws (19) and two lockwashers (20).

15 Remove strike (21).

16 Remove two machine screws (22) and two lockwashers (23).

17 Remove angle bracket (24).

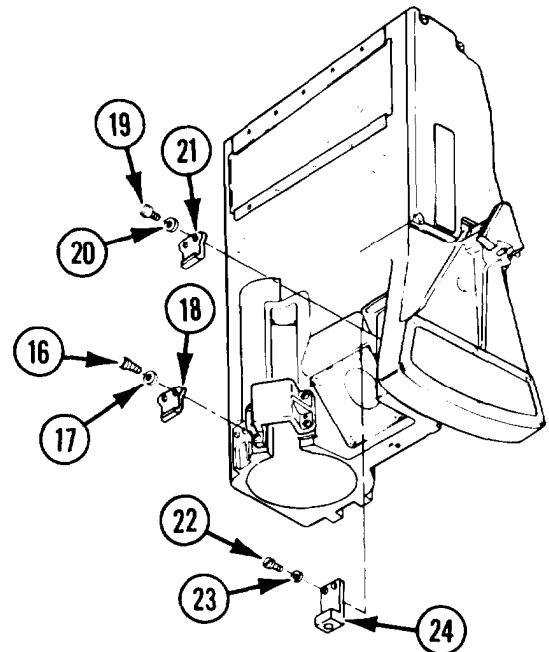

INSPECTION/REPAIR

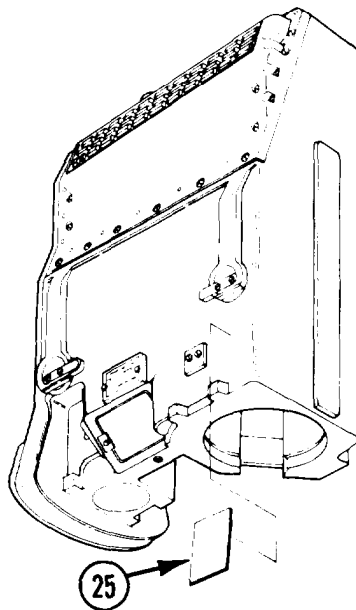

NOTE

Follow step 18 for the M32C tank periscope only.

18 Remove decal (25), only if necessary for replacement.

- 1 Inspect pneumatic valve cap for damaged threads and distortion.
- 2 Inspect hexagon nut for damaged threads and distortion.
- 3 Inspect valve cap strap for tears and/or distortion.
- 4 Inspect valve core for corrosion and deterioration.
- 5 Replace any damaged, broken, or missing parts. See TM 9-1240-379-34P.

2-3. HEAD ASSEMBLY-MAINTENANCE INSTRUCTIONS. (cont)

REASSEMBLY

WARNING

Dry cleaning solvent (SD) is flammable and should not be used near an open flame or in a smoking area. Use only in well-ventilated areas. This solvent evaporates quickly and has a drying effect on the skin. When used without gloves it may cause cracks in the skin and in some cases mild irritation or inflammation.

NOTE

Follow step 1 for the M32C tank periscope only.

- 1 Clean head assembly surface with dry cleaning solvent. Install decal (1), if removed.

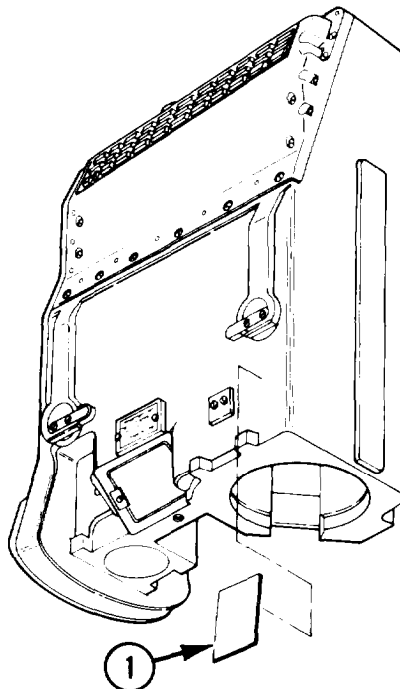

- 2 Position strike (2) on head assembly (3) and secure with two lockwashers (4) and two machine screws (5).

NOTE

Follow step 3 for the M32 or M32E1 tank periscope. Follow step 4 for the M32C or M32CE1 tank periscope.

- 3 Position angle bracket (6) on head assembly (3) and secure with two lockwashers (7) and two machine screws (8).
4. Position strike (9) on head assembly (3) and secure with two lockwashers (10) and two machine screws (11).

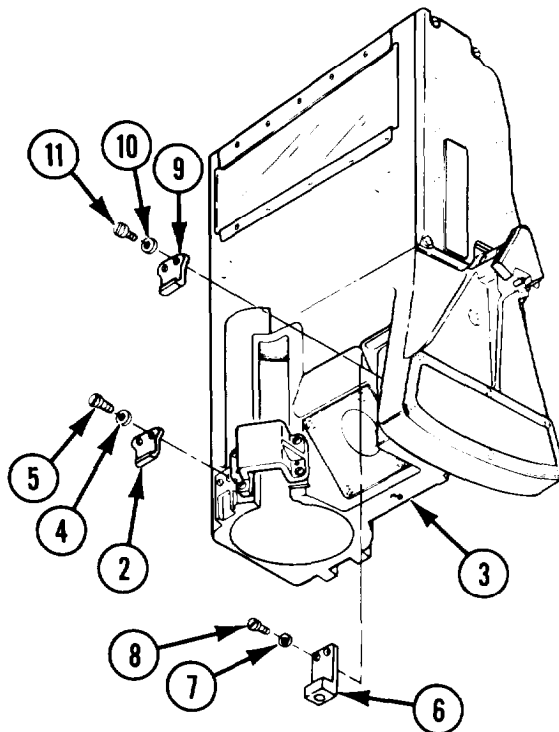

NOTE

Follow step 5 for the M32 or M32E1 tank periscope. Follow step 6 for the M32C or M32CE1 tank periscope.

- 5 Position angle bracket (12) on head assembly (3) and secure with two lockwashers (13) and two socket capscrews (14).
- 6 Position periscope latch (15) on head assembly (3) and secure with two lockwashers (16) and two machine screws (17).
- 7 Position periscope latch (18) on head assembly (3) and secure with two lockwashers (19) and two machine screws (20).

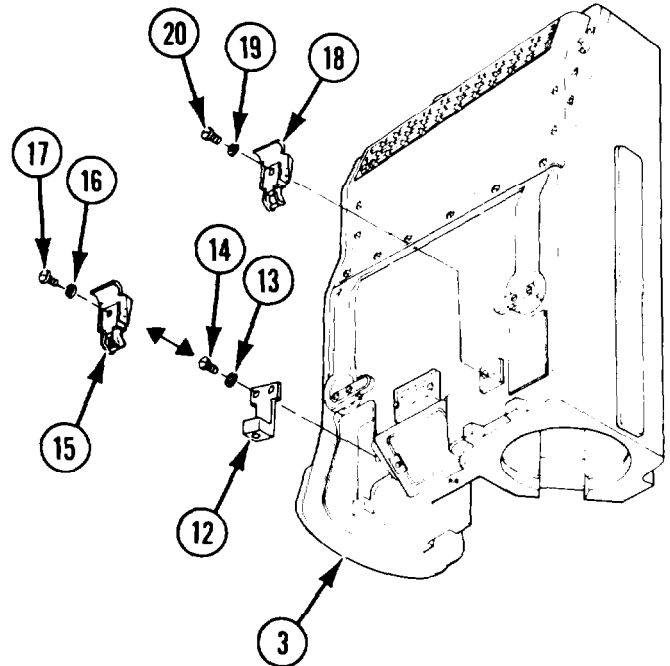

- 8 Apply sealing compound on tapered thread end of purging valve stem (21).
- 9 Install purging valve stem (21) into head assembly (3).
- 10 Install valve core (22) in purging valve stem (21).
- 11 Assemble pneumatic valve cap (23) to on purging valve cap strap (24).
- 12 Install other end of valve cap strap (24) on purging valve stem (21).
- 13 Install hexagon nut (25) on purging valve stem (21).
- 14 Install pneumatic valve cap (23) on purging valve stem (21).
- 15 After maintenance has been completed, purge and charge in accordance with TM 750-116.

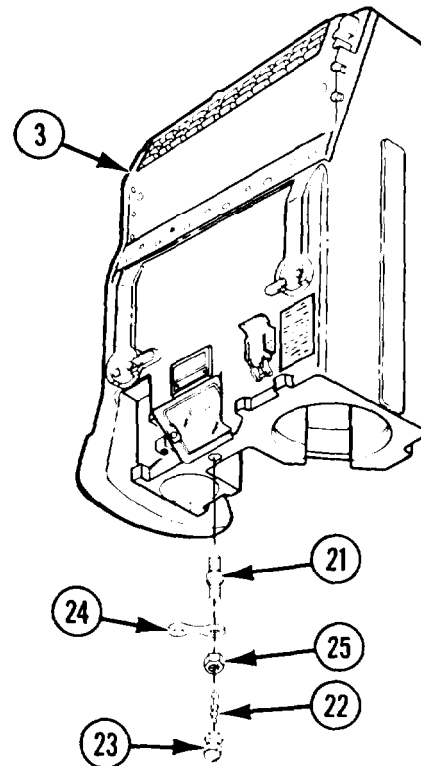

2-4. DAYLIGHT BODY ASSEMBLY—MAINTENANCE INSTRUCTIONS.

THIS TASK COVERS:

- a. Disassembly b. Inspection/cleaning/repair c. Reassembly

INITIAL SETUP

Tools and Special Tools

- Fire control maintenance and repair shop specialized equipment wrench set (SC 4931-95-C-L-J52)
- Instrument and fire control shop equipment (SC 4931-95-CL-A07)
- Instrument and fire control system repair shop equipment (SC 4931-95-CL-A09)

Materials/Parts

- Artist's brush (item 3, app B)
- Crocus cloth (item 6, app B)
- Ethyl alcohol (item 9, app B)

Grease (item 11, app B)

Lens paper (item 14, app B)

Preformed packing (two) (8205653)

Sealing compound (item 16, app B)

Solder (item 18, app B)

References

- TM 9-254
- TM 9-1240-379-34P
- TM 750-116

Equipment Conditions

- Page 2-8 Daylight body assembly removed from tank periscope

DISASSEMBLY

WARNING

Detent plunger is under spring tension. Be careful when removing or injury may result.

NOTE

Follow steps 1 thru 4 for the M32 or M32E1 tank periscope.

- 1 Remove retaining ring (1) from detent plunger (2).
- 2 Remove detent plunger (2) and helical spring (3).
- 3 Remove two machine screws (4) and key (5) from daylight body assembly (6).

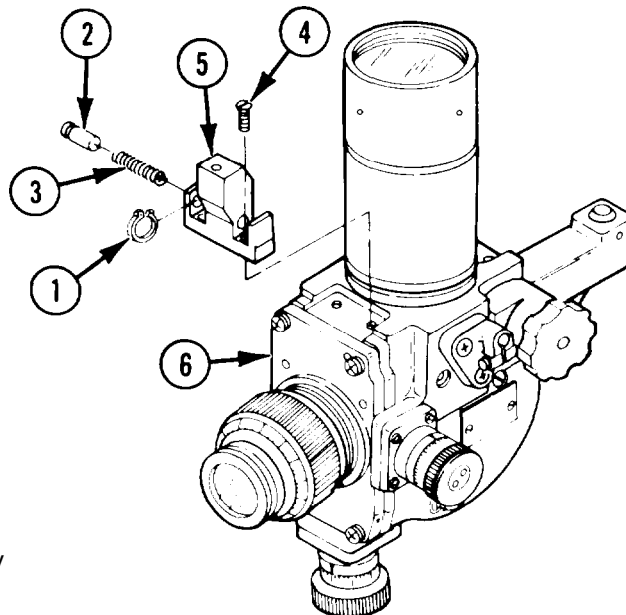

- 4 Loosen and remove two socket capscrews (7), two lockwashers (8), and block (9) from daylight body assembly (6).

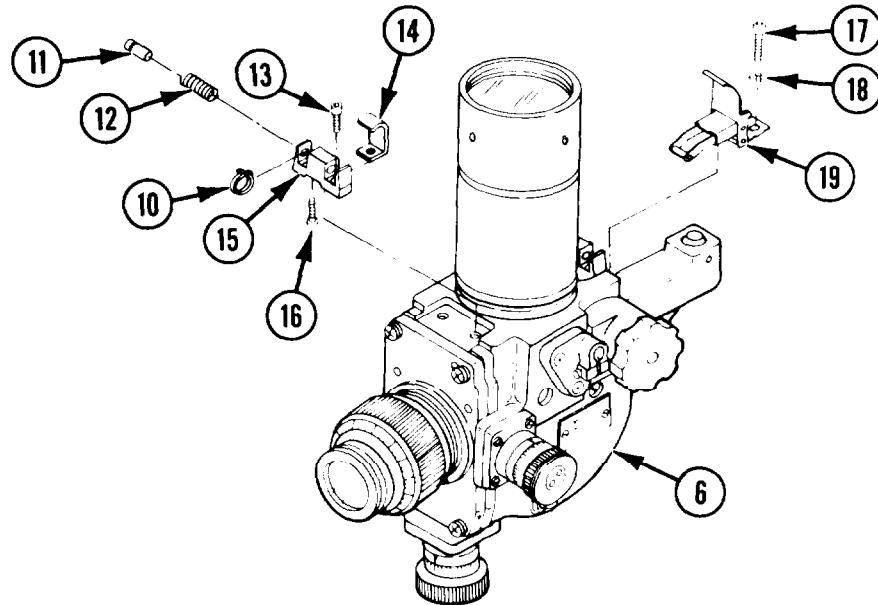
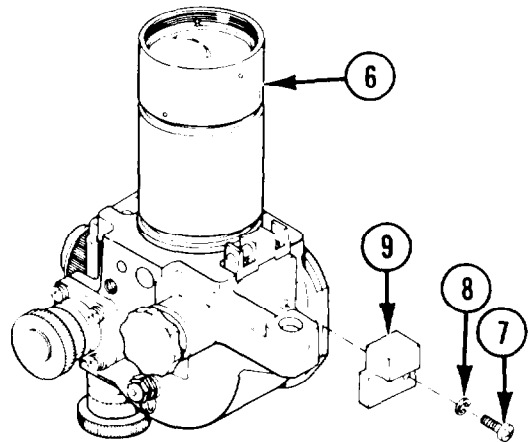

WARNING

Detent plunger is under spring tension. Be careful when removing or injury may result.

NOTE

Follow steps 5 thru 9 for the M32C or M32CE1 tank periscope.

- 5 Remove retaining ring (10) from detent plunger (11).
- 6 Remove detent plunger (11) and helical spring (12).

- 7 Remove two machine screws (13) and body assembly bracket (14) assembled with machine key (15) from daylight body assembly (6).
- 8 Remove machine screw (16) from machine key (15) and body assembly bracket (14).
- 9 Remove two machine screws (17), two lockwashers (18), and periscope latch (19) from daylight body assembly (6).

2-4. DAYLIGHT BODY ASSEMBLY-MAINTENANCE INSTRUCTIONS. (cont)

DISASSEMBLY (cont)

WARNING

Detent plunger is under spring tension. Be careful when removing or injury may result.

- 10 Remove retaining ring (20) from detent plunger (21).
- 11 Remove detent plunger (21) and helical spring (22).
- 12 Remove two machine screws (23) and key (24) from daylight body assembly (6).

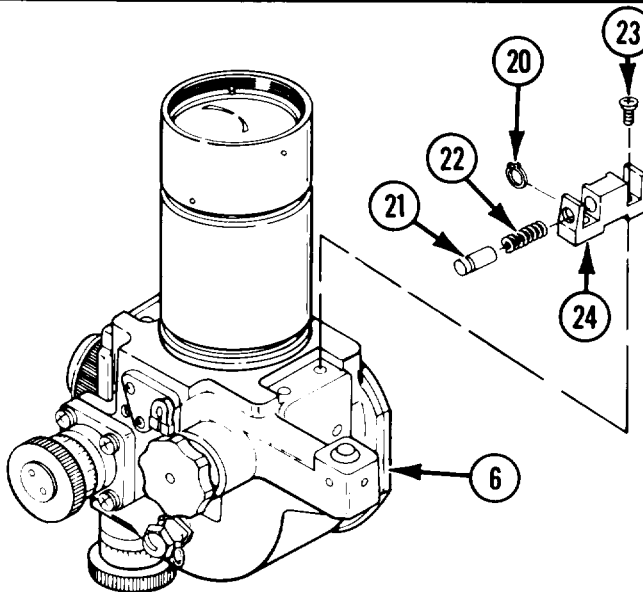

NOTE

The electrical wire provides the power source from the contact to the reticle lamp terminal. Replace only as required.

- 13 Loosen and remove setscrew (25) and lift out contact (26), together with connecting wire.
- 14 Unsolder wire from contact (26); remove contact.
- 15 Loosen and remove lampholder (27), gasket (28), and incandescent lamp (29). Discard gasket (28) if unserviceable.
- 16 Using tubular spanner wrench, remove externally threaded ring (30).

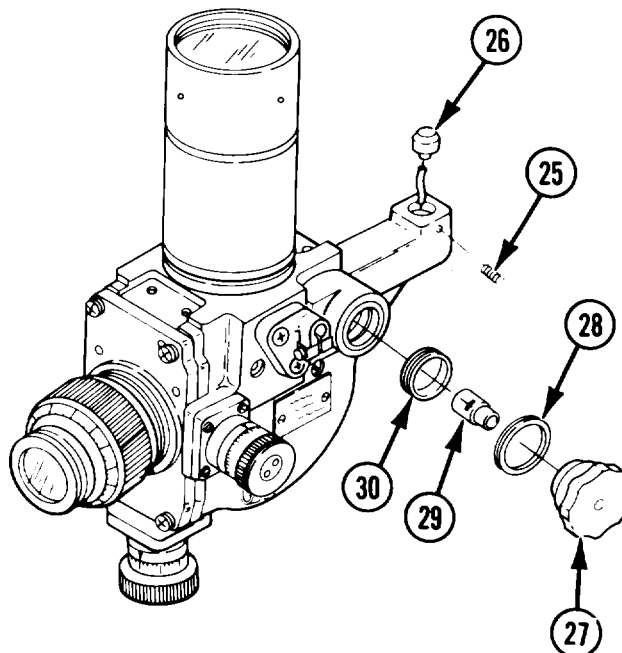

- 17 Remove four machine screws (31), four lockwashers (32), and deflection boresight knob assembly (33) from daylight body assembly (6).
- 18 Remove preformed packing (34) and discard.
- 19 Remove four machine screws (35), four lockwashers (36), and elevation boresight knob assembly (37) from daylight body assembly (6).
- 20 Remove preformed packing (38) and discard.
- 21 Remove four machine screws (39) and four lockwashers (40).
- 22 Remove optical cell assembly (41) from daylight body assembly (6).

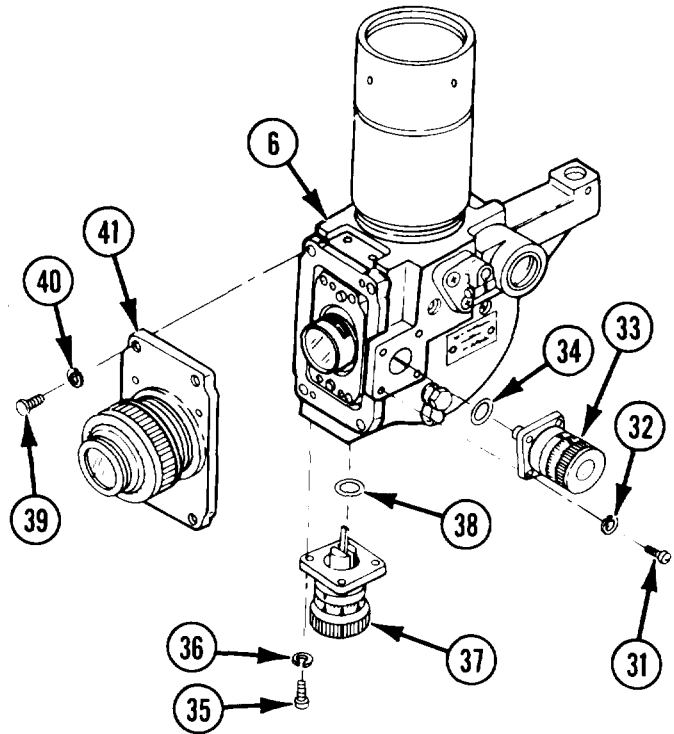

- 23 Remove purging screw (42).
- 24 Remove pneumatic valve cap (43) from purging valve stem (44) and then from valve cap strap (45).
- 25 Remove valve core (46) from purging valve stem (44).
- 26 Remove purging valve stem (44) from daylight body assembly (6).
- 27 Remove valve cap strap (45) from purging valve stem (44).

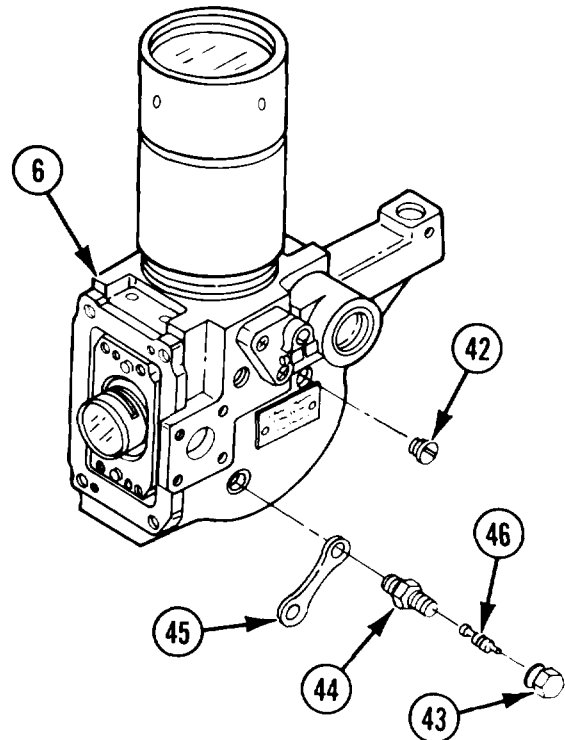

2-4. DAYLIGHT BODY ASSEMBLY – MAINTENANCE INSTRUCTIONS. (cont)

INSPECTION/CLEANING/REPAIR

- 1 Inspect contact for corrosion. Clean and polish contact with fine crocus cloth or emery paper.
- 2 Inspect purging valve stem and pneumatic valve cap for worn or damaged threads.
- 3 Inspect valve core for corrosion.
- 4 Inspect valve cap strap for tears and deformation.
- 5 Check numerical engraving on elevation and deflection knob assemblies slip scales for legibility.
- 6 Clean optical surfaces in accordance with TM 9-254.
- 7 Replace any missing, damaged, or broken parts. See TM 9-1240-379-34P.

REASSEMBLY

- 1 Assemble valve cap strap (1) to purging valve stem (2).
- 2 Apply sealing compound to tapered thread end of purging valve stem (2).
- 3 Install purging valve stem (2) into daylight body assembly (3) and tighten.
- 4 Install valve core (4) into purging valve stem (2).
- 5 Assemble pneumatic valve cap (5) to loose end of valve cap strap (1) and install pneumatic valve cap (5) on purging valve stem (2).
- 6 Apply sealing compound to threads of purging screw (6); install purging screw.

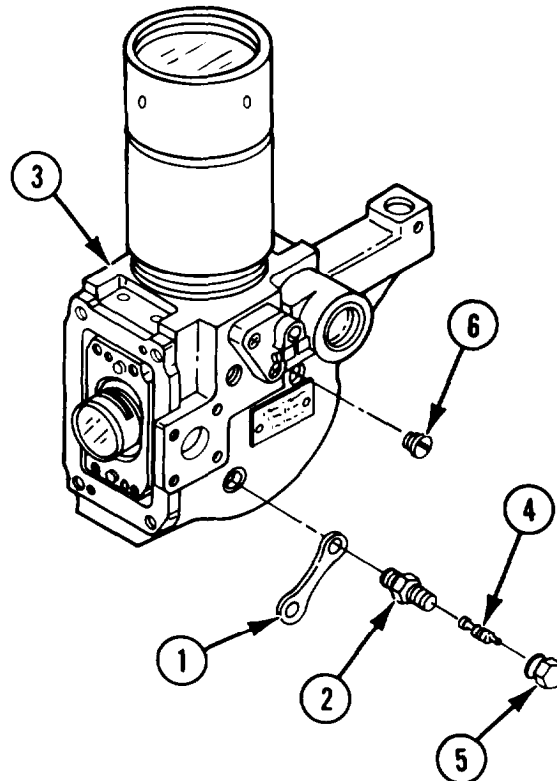

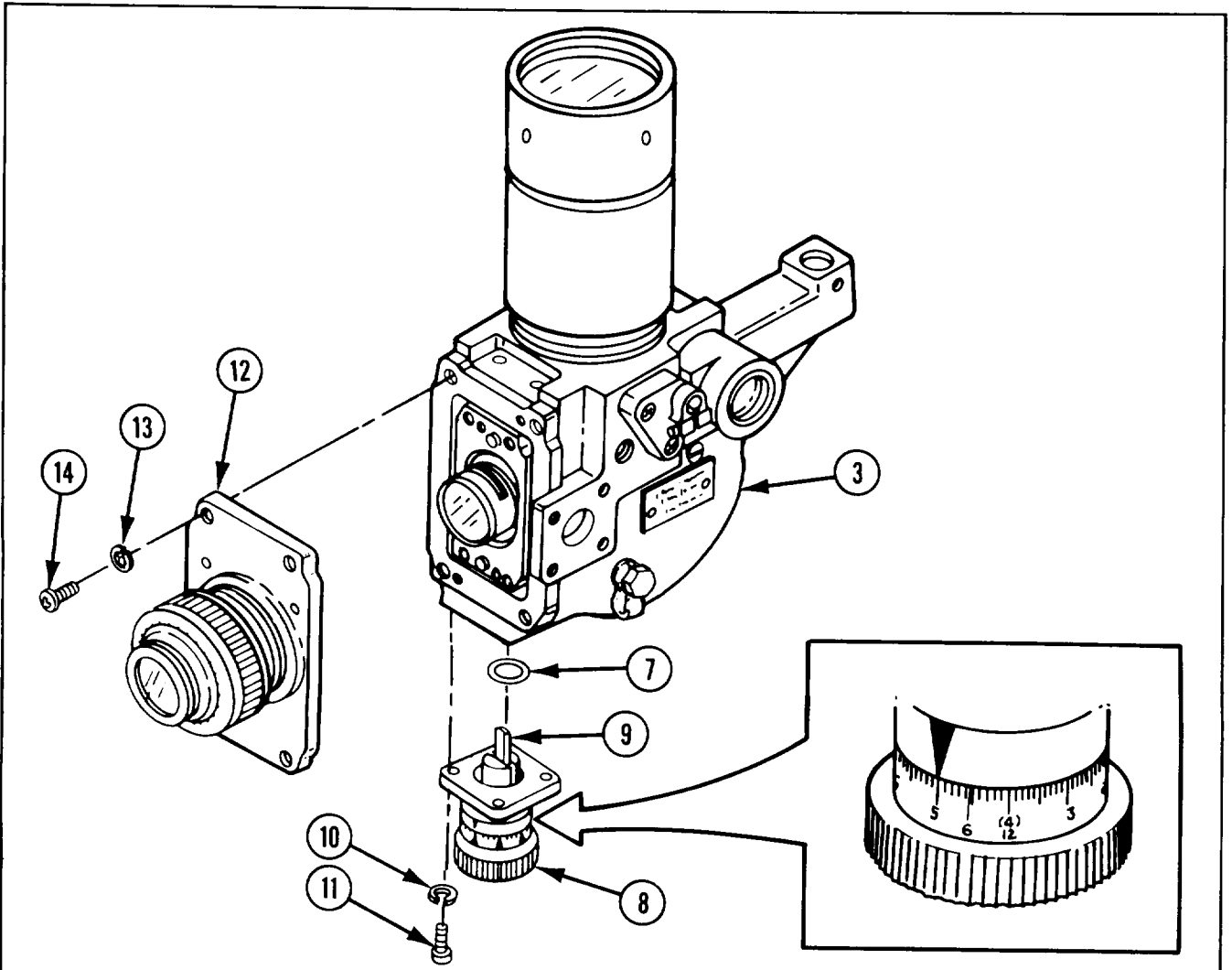

NOTE

The main difference between the elevation and deflection boresight knob assemblies is the way that the numbers face. See illustration above.

7 Apply a light coat of grease to new preformed packing (7); install preformed packing in outer grooved recess of elevation boresight knob assembly (8).

8 Align guide pin holes and hold elevation boresight knob assembly (8) against daylight body assembly (3). Turn elevation boresight knob assembly so that adjuster blade (9) just touches reticle housing.

NOTE

If adjuster blade (9) extends too far, the spring tension of the reticle will force elevation boresight knob assembly outward.

9 Install and tighten four lockwashers (10) and four machine screws (11).

10 Install optical cell assembly (12), four lockwashers (13), and four machine screws (14).

2-4. DAYLIGHT BODY ASSEMBLY – MAINTENANCE INSTRUCTIONS. (cont)

REASSEMBLY (cont)

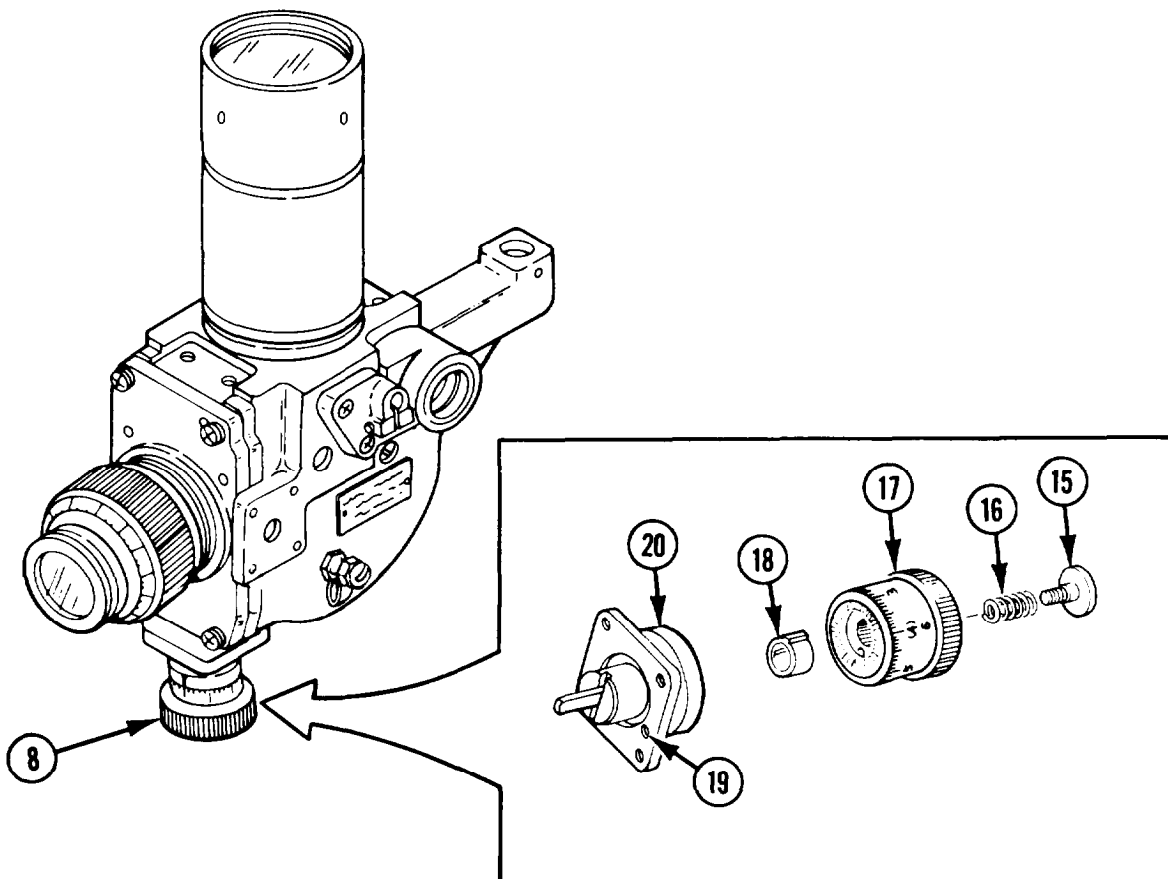

11 Adjust elevation boresight knob assembly (8):

- a. Remove screw (15) and spring (16).
- b. Remove knob (17) with scale attached. Do not remove scale from knob.
- c. Set stop (18) against right-hand side of pin (19) in clutch (20).
- d. Install knob (17) so that pin is as close as possible against left-hand side of stop (18).
- e. Install spring (16) and screw (15);

tighten screw.

- f. Turn knob (17) clockwise to its limit. Loosed screw (15) and rotate dipter scale to read +4.0. Tighten screw (15).
- g. Turn knob (17) counterclockwise to its limit. The dipter scale should read -4.0. If the scale does not read dipter scale until 0 is midpoint of the knob rotation. Tighten screw (15).

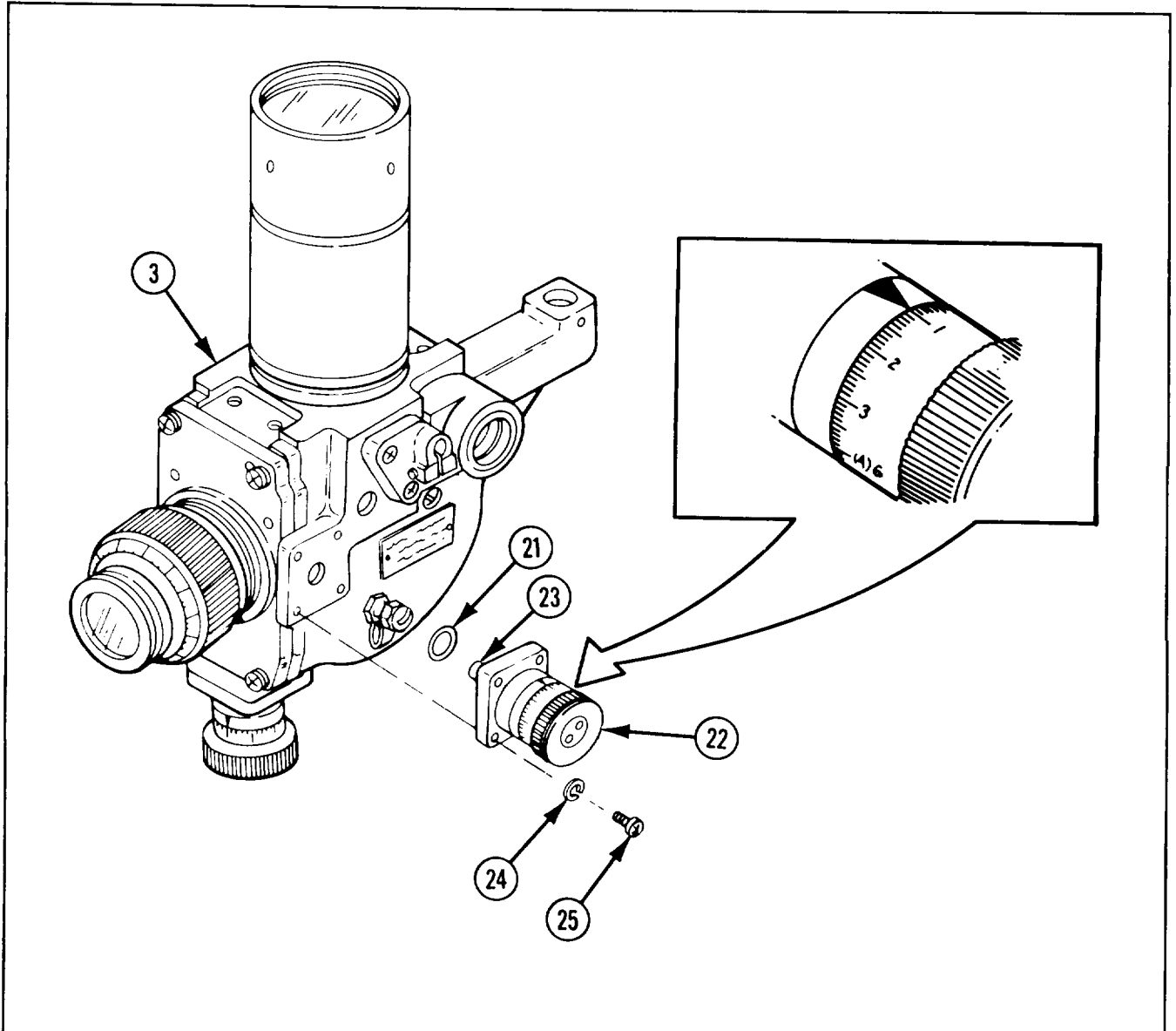

NOTE

The main difference between the elevation and deflection boresight knob assemblies is the way that the numbers face. See illustration above.

12 Apply a light coat of grease to new preformed packing (21); install preformed packing in outer grooved recess of deflection boresight knob assembly (22).

13 Hold deflection boresight knob

assembly (22) against daylight body assembly (3), turn deflection boresight knob assembly so that adjuster blade (23) just touches the reticle housing.

NOTE

If adjuster blade (23) extends too far, the spring tension of the reticle will force deflection boresight knob assembly outward.

14 Install and tighten four lockwashers (24) and four machine screws (25).

2-4. DAYLIGHT BODY ASSEMBLY-MAINTENANCE INSTRUCTIONS. (cont)

REASSEMBLY (cont)

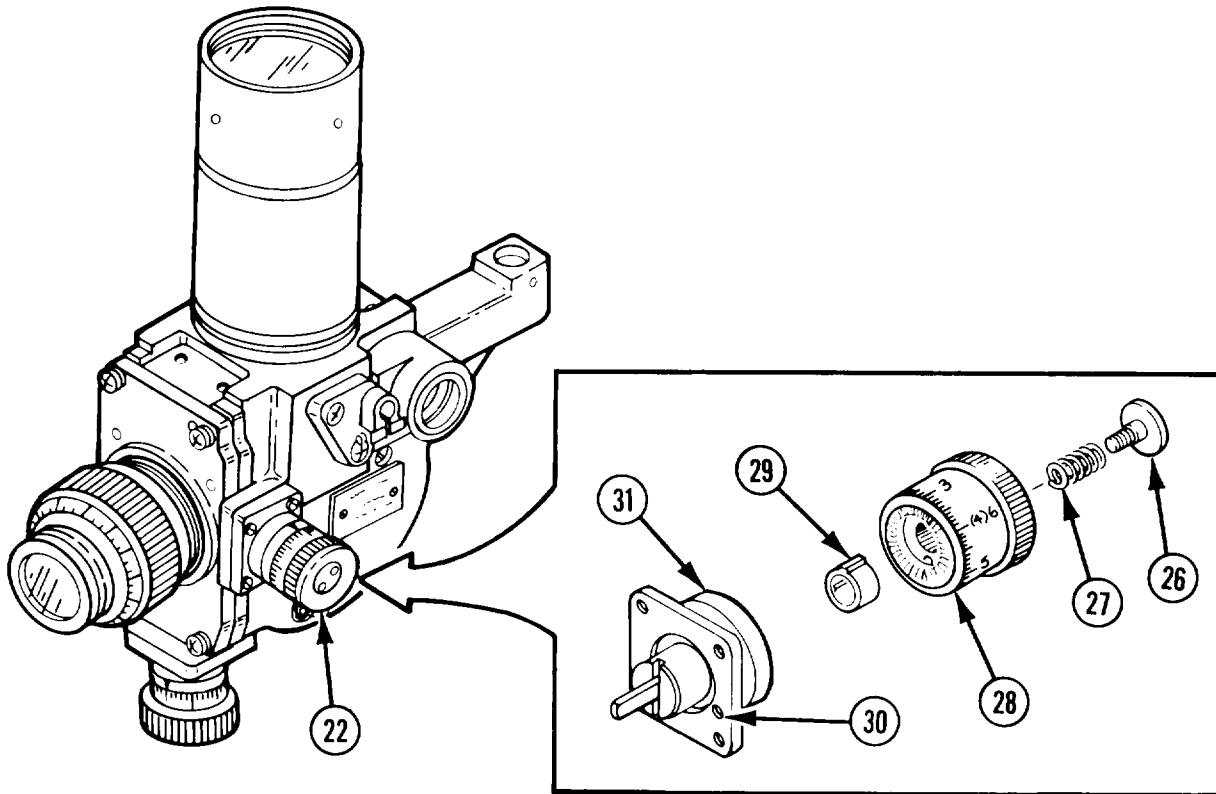

15 Adjust deflection boresight knob assembly (22):

- a. Remove screw (26) and spring (27).
- b. Remove knob (28) with scale attached. Do not remove scale.
- c. Set stop (29) against right-hand side of pin (30) in clutch (31).
- d. Install knob (28) so that pin in knob is as close as possible against the left-hand side of stop (29).
- e. Install spring (27) and screw (26); tighten screw (26).
- f. Turn knob (28) clockwise to its limit. Loosen screw (26) and rotate diopter scale to read +4.0. Tighten screw (26).
- g. Turn knob (28) counterclockwise to its limit. The diopter scale should read -4.0. If the scale does not read -4.0, loosen screw (26) and turn diopter scale until 0 is midpoint of the knob rotation. Tighten screw (26).

- 16 Using solder, attach wire to terminal of contact (32).
- 17 Coil excess wire into housing and install contact (32).
- 18 Secure contact (32) with setscrew (33) and seal setscrew (33) with sealing compound.
- 19 Install externally threaded ring (34) and tighten, using tubular wrench.
- 20 Install lampholder (35), gasket (36), and incandescent lamp (37) in daylight body assembly (3) and tighten.

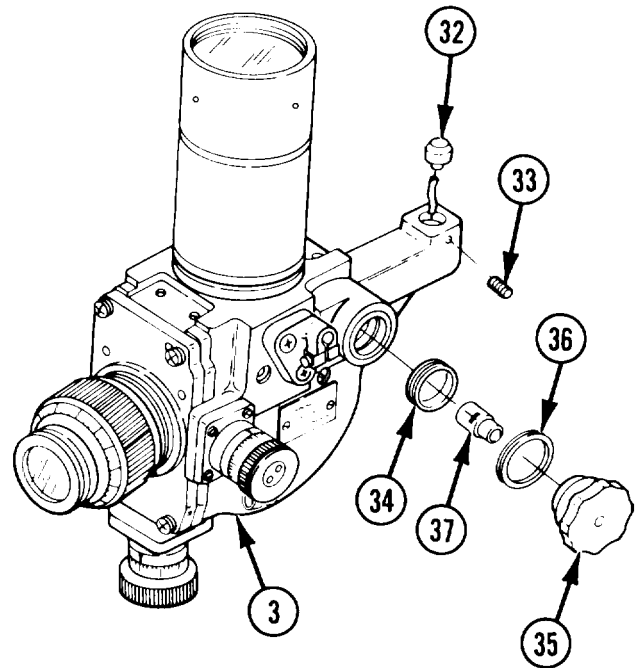

- 21 Position key (38) on daylight body assembly (3) and secure with two machine screws (39); tighten machine screws.
- 22 Install helical spring (40) into key (38).
- 23 Install detent plunger (41) against helical spring (40).
- 24 Depress detent plunger (41) to compress helical spring until retaining ring groove appears in the nearest slot of key (38).
- 25 Install retaining ring (42).

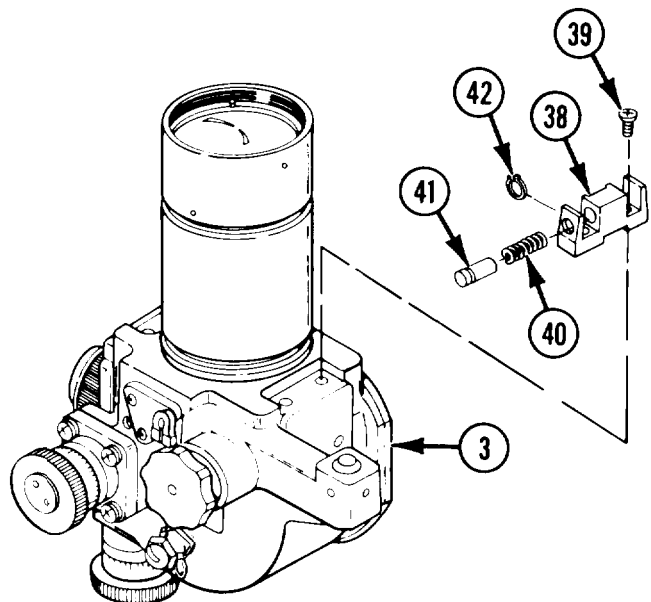

2-4. DAYLIGHT BODY ASSEMBLY - MAINTENANCE INSTRUCTIONS. (cont)

REASSEMBLY (cont)

NOTE

Follow steps 26 thru 32 for the M32C or M32CE1 tank periscope.

- 26 Position periscope latch (43) on daylight body assembly (3) and secure with two lockwashers (44) and two machine screws (45); tighten machine screws.
- 27 Install body assembly bracket (46) and machine screw (47) on machine key (48).
- 28 Position machine key (48) on daylight body assembly (3) and secure with two machine screws (49).
- 29 Install helical spring (50) in key (48).
- 30 Install detent plunger (51) against helical spring (50).
- 31 Depress detent plunger (51) to compress helical spring (50) until retaining ring groove appears in the nearest slot of key (48).
- 32 Install retaining ring (52).

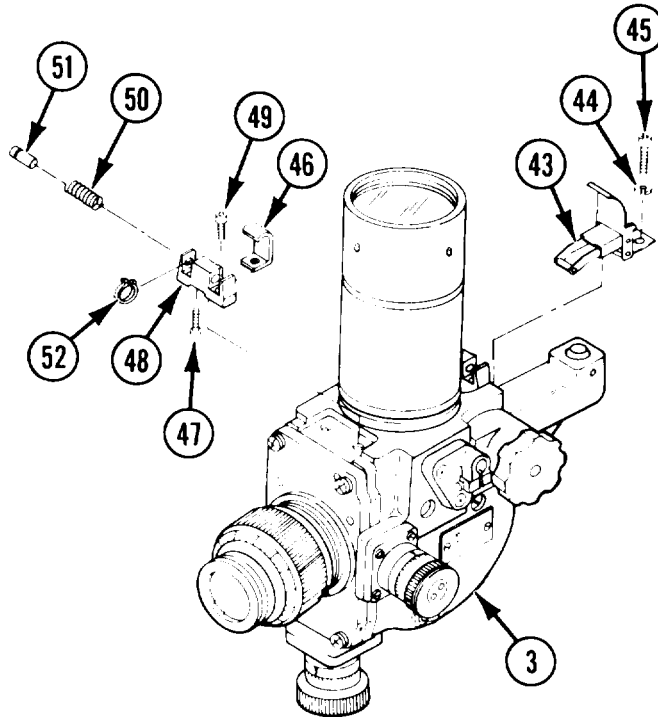

NOTE

Follow steps 33 thru 38 for the M32 or M32E1 tank periscope.

- 33 Position block (53) on daylight body assembly (3) and secure with two lockwashers (54) and two socket capscrews (55).

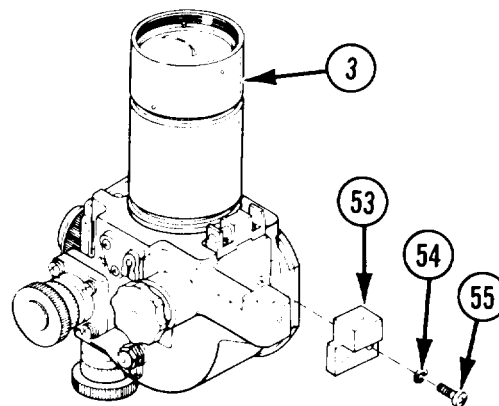

34 Position key (56) on daylight body assembly (3) and secure with two machine screws (57); tighten machine screws.

35 Install helical spring (58) in key (56).

36 Install detent plunger (59) against helical spring (58).

37 Depress detent plunger (59) to compress helical spring (58) until retaining ring groove appears in the nearest slot of key (56).

38 Install retaining ring (60).

39 After maintenance has been completed, purge and charge in accordance with TM 750-116.

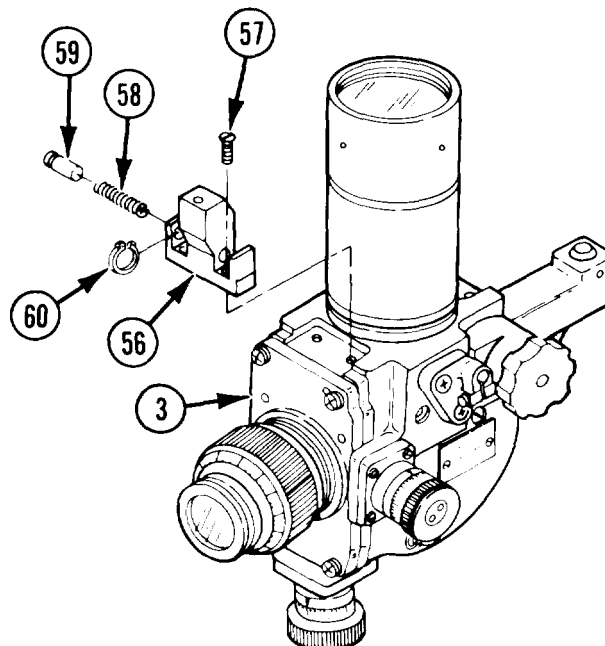

2-5. INFRARED BODY ASSEMBLY-MAINTENANCE INSTRUCTIONS.

THIS TASK COVERS:

- | | | |
|----------------|-------------------------------|---------------|
| a. Disassembly | b. Inspection/cleaning/repair | c. Reassembly |
|----------------|-------------------------------|---------------|

INITIAL SETUP

Applicable Configurations
M32 and M32C tank periscopes

Tools and Special Tools
Instrument and fire control shop equipment (SC 4931-95-CL-A07)
Instrument and fire control system repair shop equipment (SC 4931-95-CL-A09)

Materials/Parts
Artist's brush (item 3, app B)
Ethyl alcohol (item 9, app B)
Gasket (10542005)

Grease (item 11, app B)
Lens paper (item 14, app B)
Preformed packing (two) (8205653)
Sealing compound (item 16, app B)
Spring tension washer (10516207)

References
TM 9-254
TM 9-1240-379-34P
TM 750-116

Equipment Conditions
Page 2-8 Infrared body assembly removed from tank periscope

2-5. INFRARED BODY ASSEMBLY—MAINTENANCE INSTRUCTIONS. (cont)

DISASSEMBLY

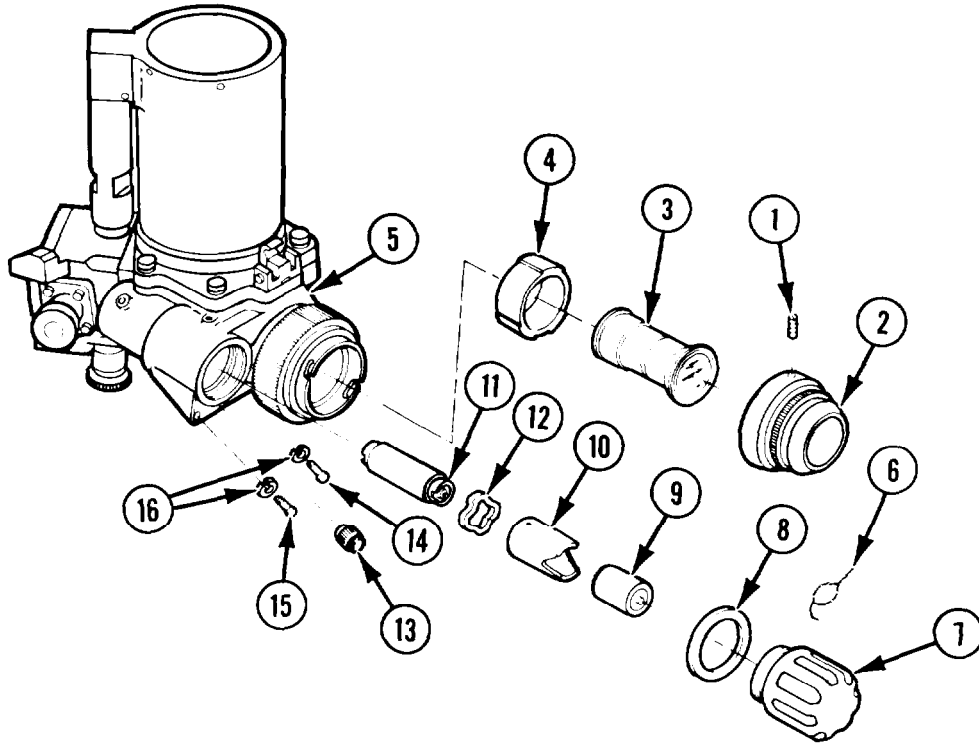

- 1 Loosen two setscrews (1) and turn eyepiece assembly (2) counterclockwise to remove.

CAUTION

Damage may result if electron tube is exposed to bright sunlight or high intensity artificial light.

- 2 Remove eyepiece assembly (2), electron tube (3), and collar (4) from infrared body assembly (5).

NOTE

The antipilferage seal will not be replaced.

- 3 Cut wire of antipilferage seal (6), if present, and remove from cap assembly (7). Discard antipilferage seal.
- 4 Remove cap assembly (7) with attached gasket (8).

- 5 Remove gasket (8) and discard.
- 6 Remove converter regulator (9) or battery.

NOTE

The solid power supply has two bayonet-type slots which, when assembled with the spring tension washer and pinned sleeve, are interlocked and will be removed as an assembly.

- 7 Rotate pinned sleeve (10) counterclockwise as far as possible, disengaging output end of solid power supply (11) from interlocking pins of connector.

- 8 Remove pinned sleeve (10), spring tension washer (12), and solid power supply (11) from infrared body assembly (5).
- 9 Remove solid power supply (11) from pinned sleeve (10). Remove and discard spring tension washer (12).
- 10 Remove knob (13), three machine screws (14), machine screw (15), and four lockwashers (16), only if required for replacement.

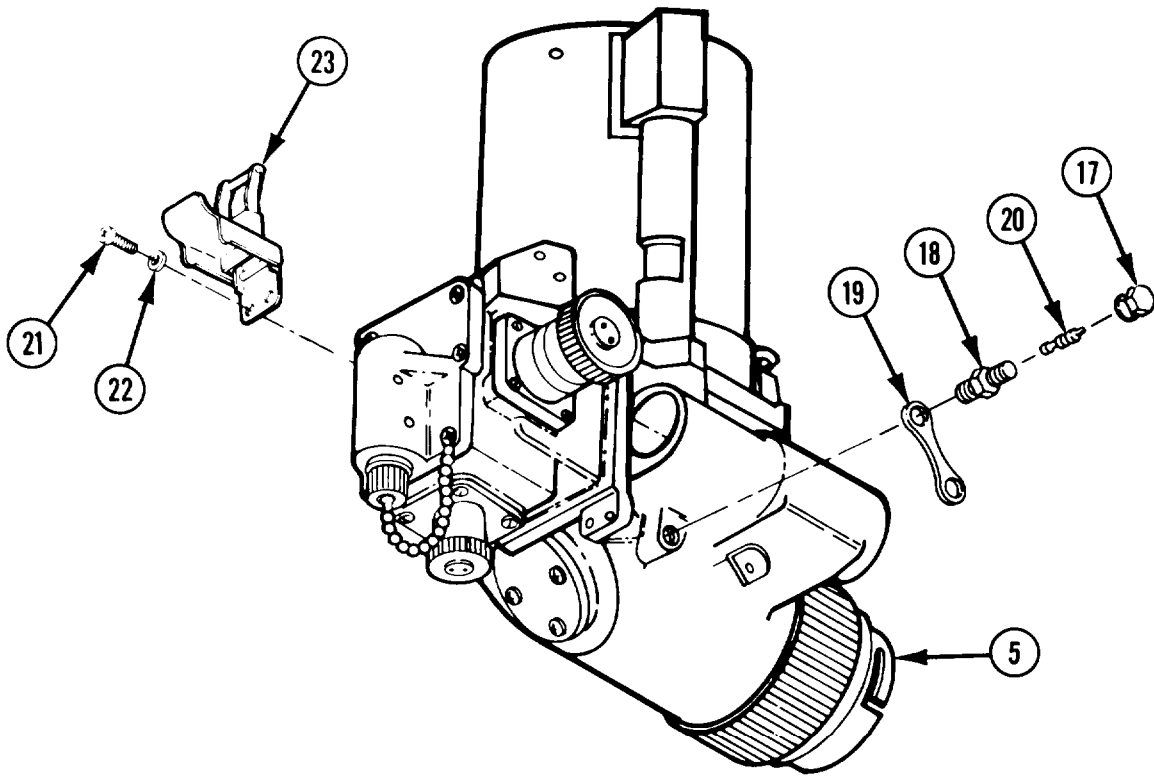

- 11 Remove pneumatic valve cap (17) from purging valve stem (18).
- 12 Remove pneumatic valve cap (17) from valve cap strap (19).
- 13 Remove valve core (20) from purging valve stem (18).
- 14 Remove purging valve stem (18) from infrared body assembly (5).
- 15 Remove valve cap strap (19) from purging valve stem (18).
- 16 Loosen and remove two machine screws (21) and two lockwashers (22).
- 17 Remove periscope latch (23).

2-5. INFRARED BODY ASSEMBLY—MAINTENANCE INSTRUCTIONS. (CONT)

DISASSEMBLY (cont)

- 18 Loosen and remove four machine screws (24) and four lockwashers (25).
- 19 Remove deflection boresight knob assembly (26) from infrared body assembly (5).
- 20 Remove preformed packing (27) and discard.
- 21 Loosen and remove four machine screws (28) and four lockwashers (29)
- 22 Remove elevation boresight knob assembly (30) from infrared body assembly (5).
- 23 Remove preformed packing (31) and discard.
- 24 Remove six machine screws (32) and six lockwashers (33).
- 25 Remove cover assembly (34); remove assembled lampholder plug (35) from cover assembly.

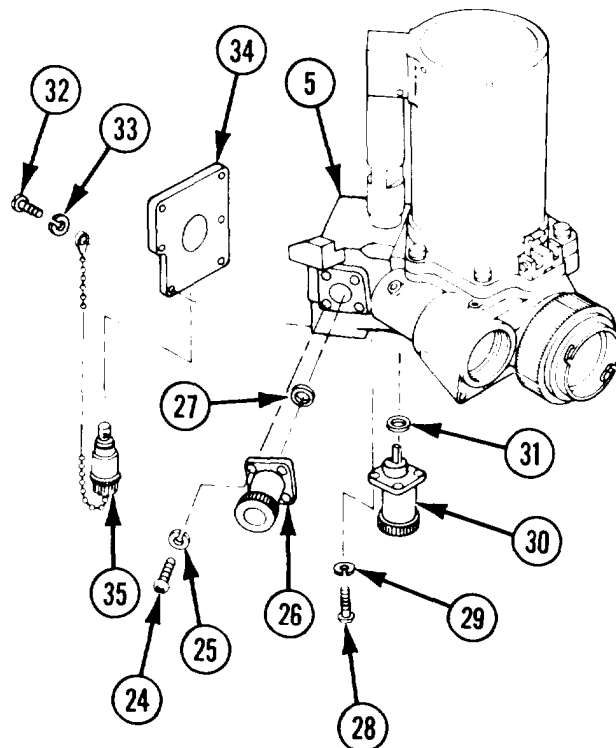

INSPECTION/CLEANING/REPAIR

- | | |
|---|--|
| <ol style="list-style-type: none"> 1 Inspect eyepiece assembly for chips, cracks, or damage that may interfere with the operation of the tank periscope. Inspect for damaged threads. If defective, forward to next higher level of maintenance and obtain a new eyepiece assembly. 2 Inspect electron tube for chips, cracks, or damage that may interfere with operation of the tank periscope. 3 Inspect cap assembly for evidence of cracks and damaged threads. | <ol style="list-style-type: none"> 4 Inspect converter regulator, pinned sleeve, and solid power supply for evidence of corrosion. 5 Inspect pneumatic valve cap and purging valve stem for damaged threads and distortion. 6 Inspect valve cap strap for tears and/or distortion. 7 Inspect valve core for corrosion and deterioration. |
|---|--|

- | | |
|---|---|
| <p>8 Check numerical engraving on elevation and deflection knob assemblies slip scales for legibility.</p> <p>9 Clean optical surfaces in accordance with TM 9-254.</p> | <p>10 Replace any damaged, missing, or broken parts. See TM 9-1240-379-34P.</p> |
|---|---|

REASSEMBLY

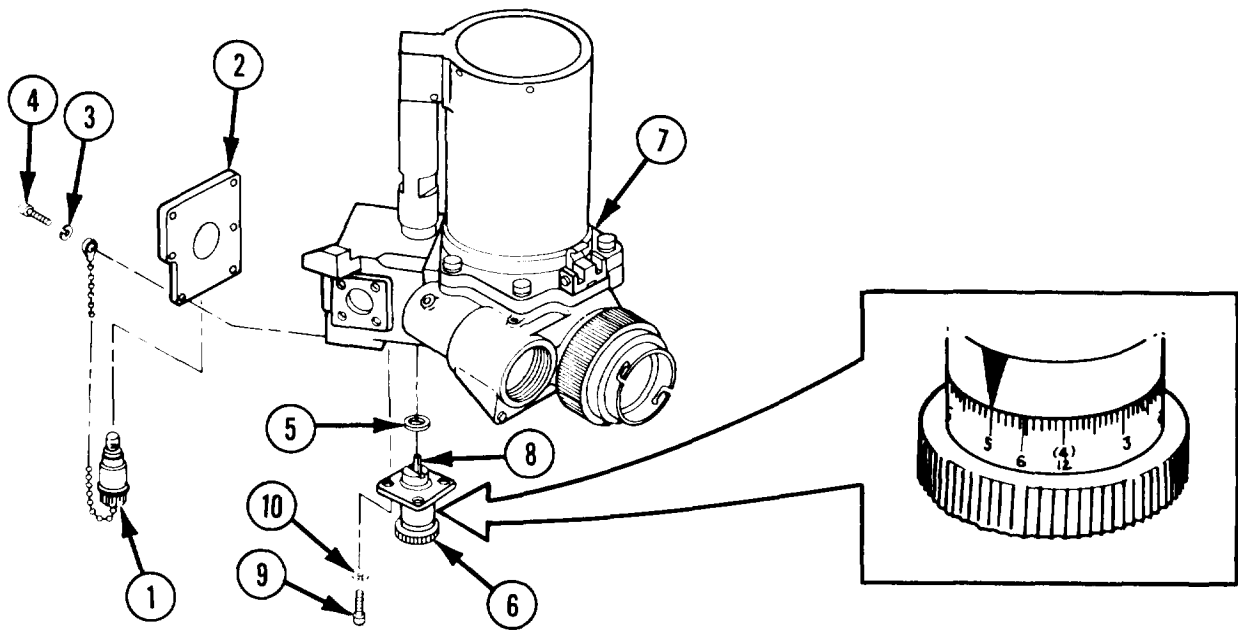

- 1 Install assembled lampholder plug (1) in cover assembly (2).
- 2 Install cover assembly (2) and secure with six lockwashers (3) and six machine screws (4).
- 3 Apply a light coat of grease to new preformed packing (5).

NOTE

The main difference between the elevation and deflection boresight knob assemblies is the way that the numbers face. See illustration above.

- 4 Install new preformed packing (5) into

grooved recess of elevation boresight knob assembly (6).

- 5 Hold elevation boresight knob assembly (6) against infrared body assembly (7) and turn knob so that adjuster blade (8) just touches reticle housing.

NOTE

If adjuster blade (8) extends too far, the spring tension of the reticle will force the elevation boresight knob assembly outward.

- 6 Install four machine screws (9), assembled with four lockwashers (10), and tighten.

2-5. INFRARED BODY ASSEMBLY—MAINTENANCE INSTRUCTIONS. (cont)

REASSEMBLY (cont)

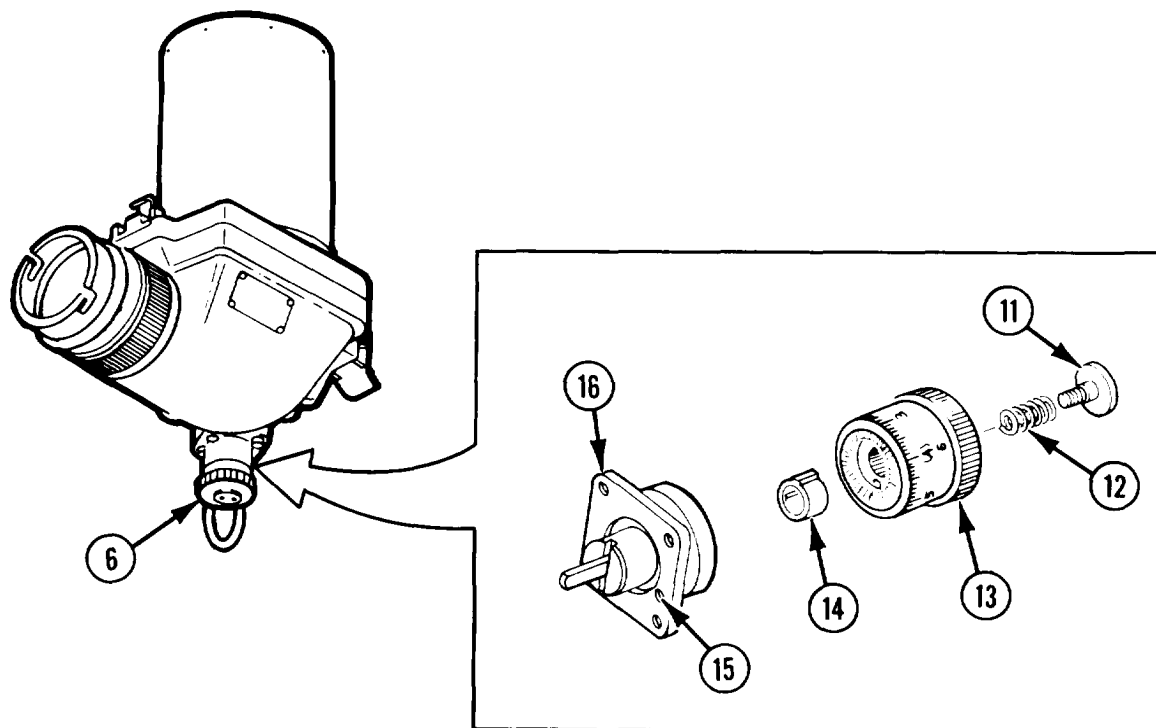

7 Adjust elevation boresight knob assembly (6):

- a. Remove screw (11) and spring (12).
- b. Remove knob (13) with scale attached. Do not remove scale.
- c. Set stop (14) against right-hand side of pin (15) in clutch (16).
- d. Install knob (13) so that pin is as close as possible against left-hand side of stop (14).
- e. Install spring (12) and screw (11); tighten screw (11).
- f. Turn knob (13) clockwise to its limit. Loosen screw (11) and rotate diopter scale to read +4.0. Tighten screw (11).
- g. Turn knob (13) counterclockwise to its limit. The diopter scale should read -4.0. If it does not read -4.0, loosen screw (11) and turn diopter scale so that 0 is midpoint of the knob rotation. Tighten screw (11).

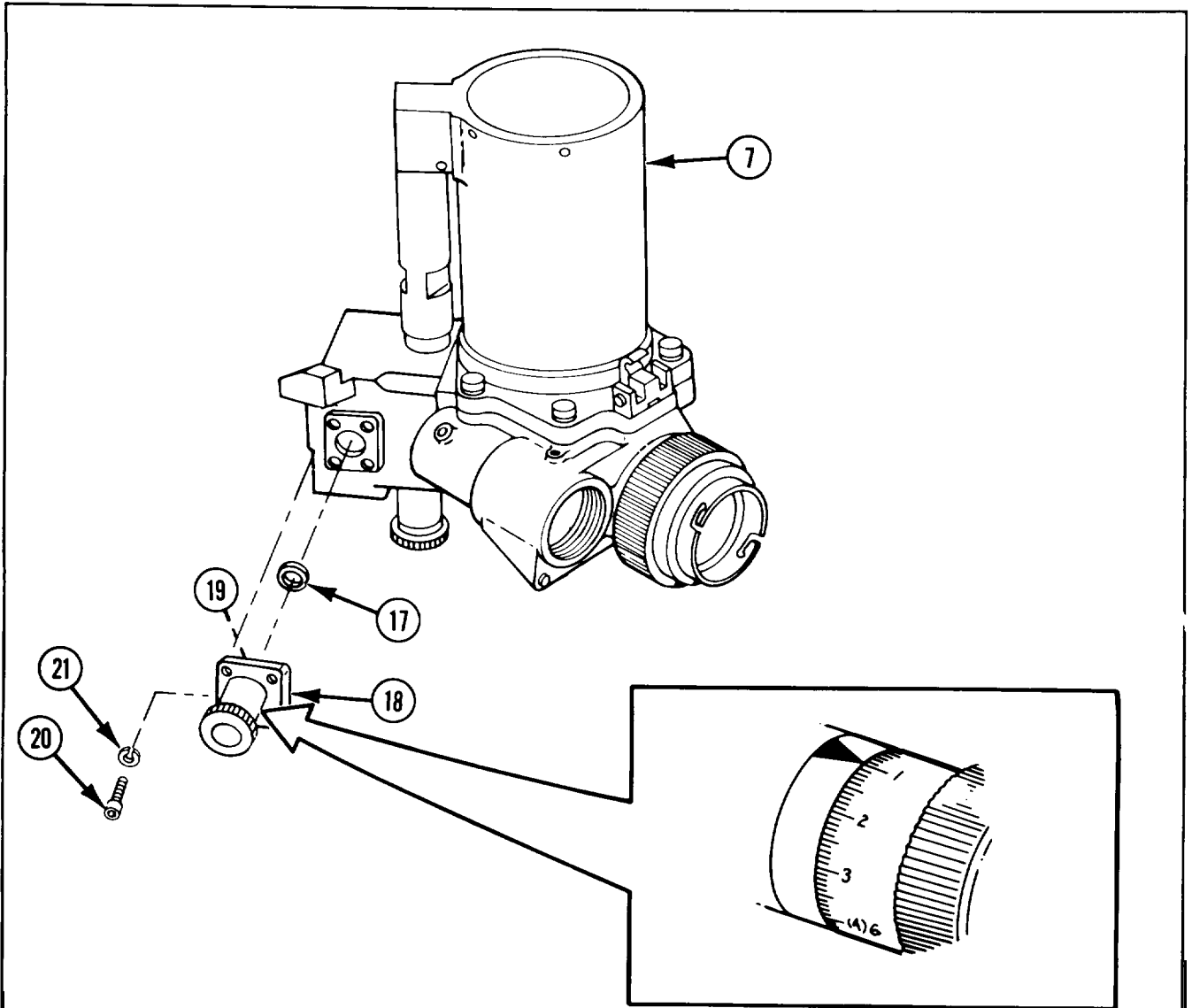

- 8 Apply a light coat of grease to new preformed packing (17).
- 9 Install new preformed packing (17) into grooved recess of deflection boresight knob assembly (18).
- 10 Holding deflection boresight knob assembly (18) against infrared body assembly (7), turn knob so that adjuster blade (19) just touches reticle housing.

- NOTE
- If adjuster blade (19) extends too far, the spring tension of the reticle will force the deflection boresight knob assembly outward.
- 11 Install four machine screws (20), assembled with four lockwashers (21), and tighten.

2-5. INFRARED BODY ASSEMBLY - MAINTENANCE INSTRUCTIONS. (cont)

REASSEMBLY (cont)

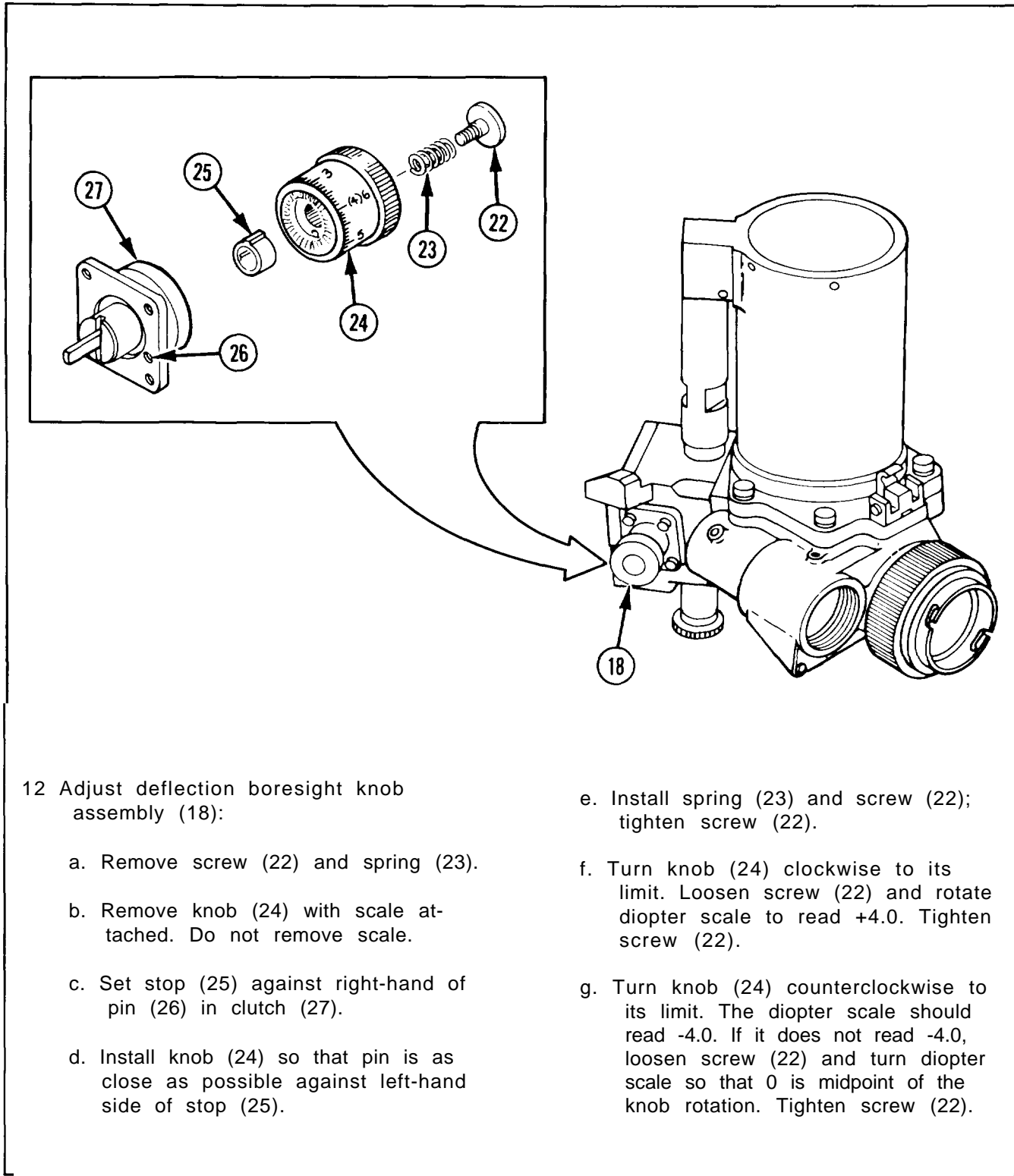

12 Adjust deflection boresight knob assembly (18):

- a. Remove screw (22) and spring (23).
- b. Remove knob (24) with scale attached. Do not remove scale.
- c. Set stop (25) against right-hand of pin (26) in clutch (27).
- d. Install knob (24) so that pin is as close as possible against left-hand side of stop (25).
- e. Install spring (23) and screw (22); tighten screw (22).
- f. Turn knob (24) clockwise to its limit. Loosen screw (22) and rotate diopter scale to read +4.0. Tighten screw (22).
- g. Turn knob (24) counterclockwise to its limit. The diopter scale should read -4.0. If it does not read -4.0, loosen screw (22) and turn diopter scale so that 0 is midpoint of the knob rotation. Tighten screw (22).

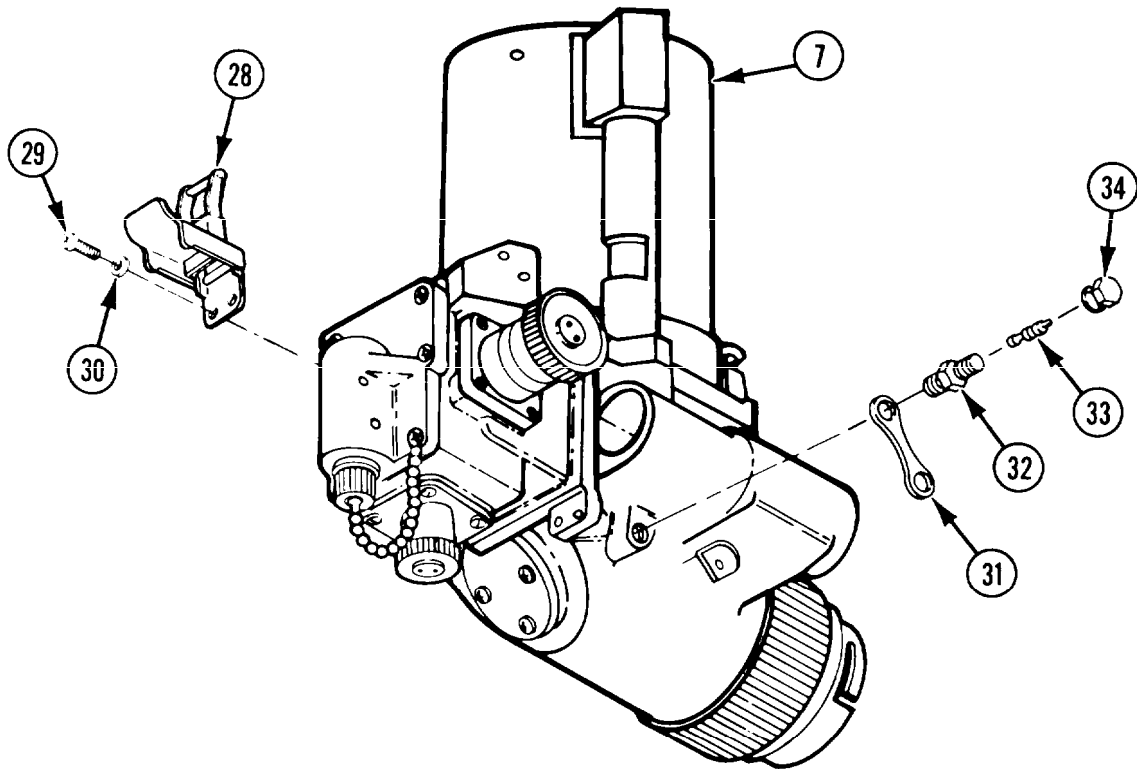

- 13 Align holes of periscope latch (28) with holes in infrared body assembly (7).
- 14 Install two machine screws (29), assembled with two lockwashers (30), and tighten.
- 15 Assemble one end of valve cap strap (31) to tapered thread end of purging valve stem (32).
- 16 Apply sealing compound to tapered thread end of purging valve stem (32).

- 17 Install purging valve stem (32) in infrared body assembly (7) and tighten.
- 18 Install valve core (33) in purging valve stem (32).
- 19 Assemble pneumatic valve cap (34) to other end valve cap strap (31) and then install on purging valve stem (32).

2-5. INFRARED BODY ASSEMBLY - MAINTENANCE INSTRUCTIONS. (cont)

REASSEMBLY (cont)

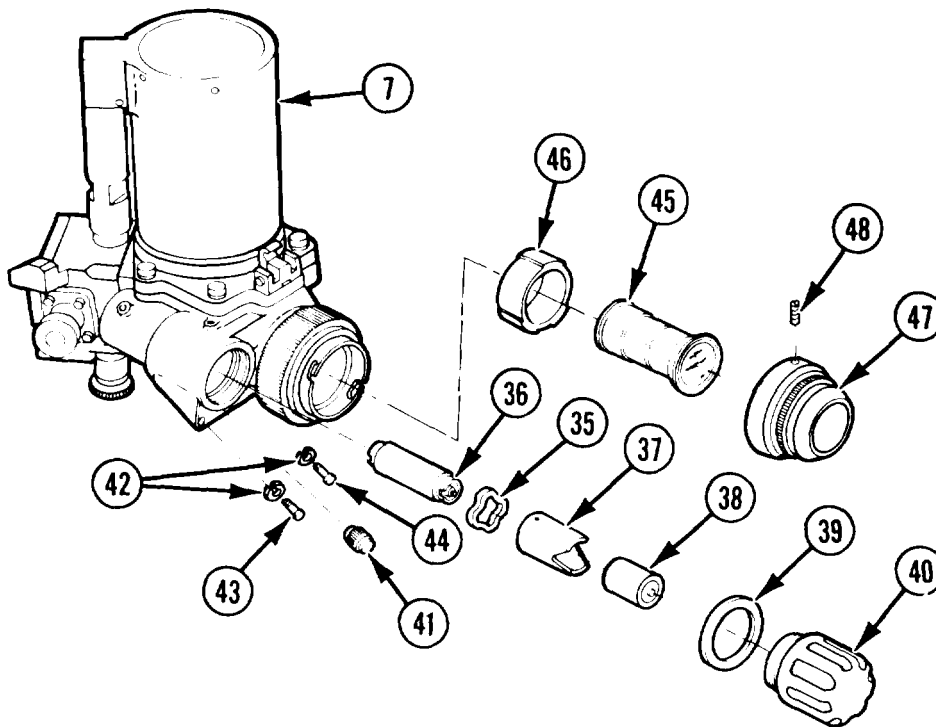

- | | |
|--|---|
| <p>20 Assemble new spring tension washer (35) to input end of solid power supply (36).</p> <p>21 Aline pins of pinned sleeve (37) to bayonet-type slots of solid power supply (36).</p> <p>22 Compress spring tension washer (35) and rotate pinned sleeve (37) clockwise to secure.</p> <p>23 Install assembled components in infrared body assembly (7), alining bayonet-type slots with interlocking pins of connector; rotate clockwise to secure.</p> <p>24 Install converter regulator (38) in pinned sleeve (37).</p> <p>25 Assemble new gasket (39) to cap assembly (40).</p> <p>26 Install cap assembly (40) in infrared body assembly (7) and tighten.</p> | <p>27 If removed, install knob (41), four new lockwashers (42), new machine screw (43), and three new machine screws (44).</p> <p style="text-align: center;">CAUTION
Damage may result if electron tube is exposed to bright sunlight or high intensity artificial light.</p> <p>28 Install electron tube (45) and collar (46) in infrared body assembly (7).</p> <p>29 Install eyepiece assembly (47); tighten clockwise snugly by hand.</p> <p>30 Tighten two setscrews (48).</p> <p>31 After maintenance has been completed, purge and charge in accordance with TM 750-116.</p> |
|--|---|

2-6. OPTICAL CELL ASSEMBLY—MAINTENANCE INSTRUCTIONS.

THIS TASK COVERS:

- a. Disassembly b. Inspection/cleaning/repair c. Reassembly

INITIAL SETUP

Applicable Configurations
M32 and M32C tank periscope

Ethyl alcohol (item 9, app B)
Lens paper (item 14, app B)

Tools and Special Tools
Helicoil insert and tool kit (4131-04-1)
Instrument and fire control shop equip-
ment (SC 4931-95-CL-A07)
Instrument and fire control system repair
shop equipment (SC 4931-95-CL-A09)

References
TM 9-254
TM 9-1240-379-34P
TM 750-116

Materials/Parts
Artist's brush (item 3, app B)

Equipment Conditions
Page 2-8 Infrared body assembly re-
moved from tank periscope

DISASSEMBLY

WARNING

Detent plunger is under spring tension. Be careful when removing or injury may result.

- 1 Remove retaining ring (1) from detent plunger (2) while pressing a screwdriver blade against detent plunger to release spring tension. Remove detent plunger (2) and helical spring (3) from optical cell assembly (4).
- 2 Remove two machine screws (5) and remove machine key (6) and body assembly bracket (7).
- 3 Remove machine screw (8) to separate body assembly bracket (7) from machine key (6).
- 4 Remove two screw thread inserts (9) only if necessary for replacement. Refer to TM 9-254.

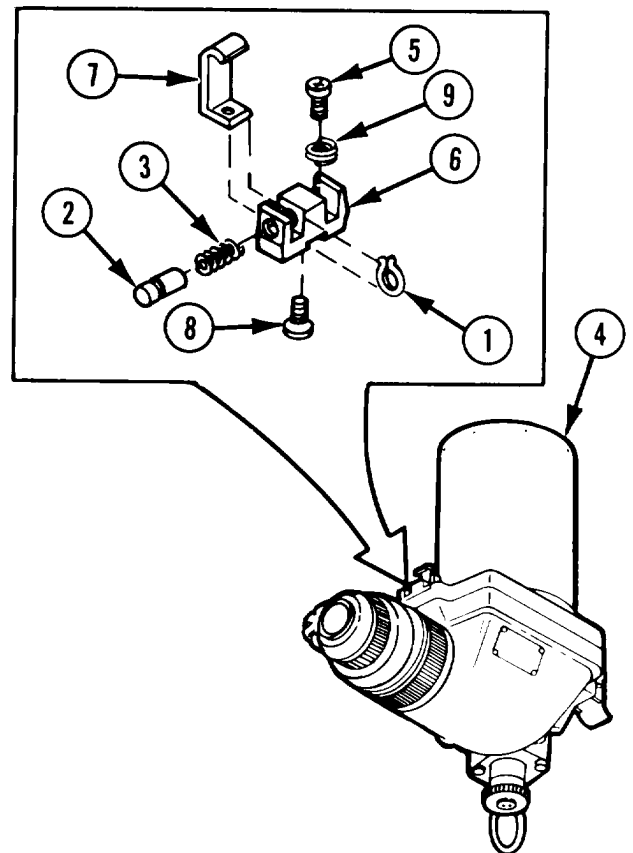

2-6. OPTICAL CELL ASSEMBLY-MAINTENANCE INSTRUCTIONS. (cont)

INSPECTION/CLEANING/REPAIR

- 1 Check machine screws for worn or damaged threads. Clean dirt and grime from all threads.
- 2 Inspect helical spring for breaks.
- 3 Clean optical surfaces in accordance with TM 9-254.
- 4 Replace any damaged, broken, or missing parts. See TM 9-1240-379-34P.

REASSEMBLY

- 1 If removed, install screw thread inserts (1). Refer to TM 9-254.
- 2 Assemble machine key (2) to body assembly bracket (3) and secure with machine screw (4).
- 3 Position assembled machine key and body assembly bracket on optical cell assembly (5) and secure with two machine screws (6).
- 4 Install helical spring (7) and detent plunger (8) in machine key (2); secure with retaining ring (9).
- 5 After maintenance is completed, purge and charge in accordance with TM 750-116.

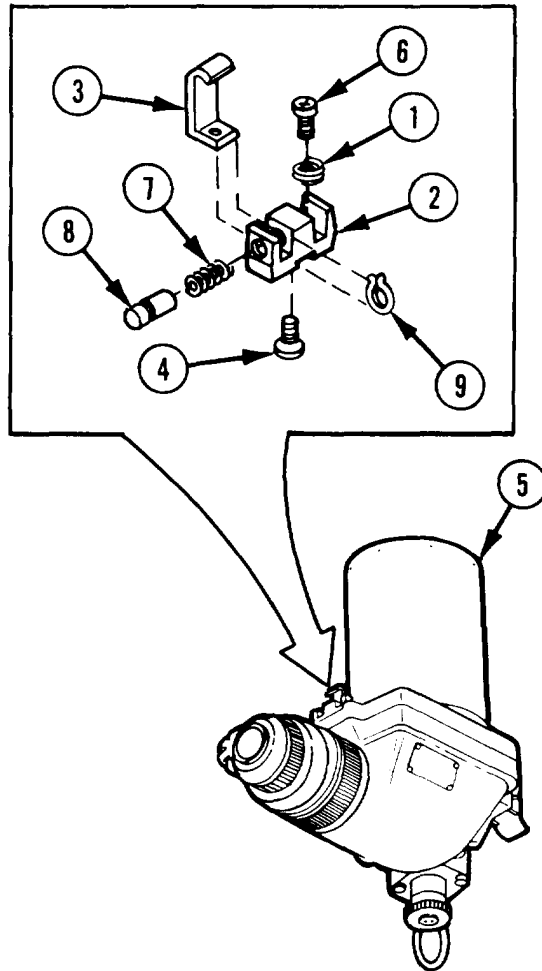

2-7. ELBOW ASSEMBLY—MAINTENANCE INSTRUCTIONS.

THIS TASK COVERS:

a. Disassembly

b. Inspection/cleaning/repair

c. Reassembly

INITIAL SETUP

Applicable Configurations

M32E1 and M32CE1 tank periscope

Tools and Special Tools

Instrument and fire control shop equipment (SC 4931-95-CL-A07)

Instrument and fire control system repair shop equipment (SC 4931-95-CL-A09)

Special threaded tool (app C)

Materials/parts

Artist's brush (item 3, app B)

Ethyl alcohol (item 9, app B)

Lens paper (item 14, app B)

Preformed packing (MS9021-038)

Preformed packing (two) (MS9021-114)

Sealing compound (item 16, app B)

References

TM 9-254

TM 9-1240-379-34P

TM 750-116

Equipment Conditions

Page 2-8 Elbow assembly removed from tank periscope

DISASSEMBLY

- 1 Remove optical eyeshield (1).

CAUTION

Damage may result if image intensifier is exposed to bright sunlight or high intensity artificial light.

- 2 Loosen two setscrews (2) located on locking ring of eyepiece assembly (3).
- 3 Remove eyepiece assembly (3) by unscrewing locking ring.
- 4 Loosen three setscrews (4) securing threaded adapter (5) to elbow assembly (6).
- 5 Remove threaded adapter (5) from elbow assembly (6).
- 6 Remove preformed packing (7) from threaded adapter (5). Discard preformed packing (7).
- 7 Remove image intensifier (8). If image intensifier does not readily slide out, it may be necessary to use the special threaded tool (9).

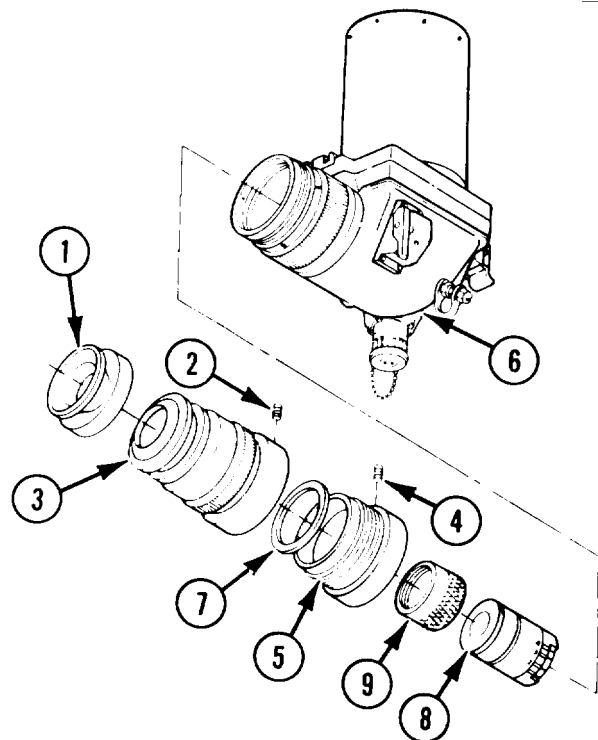

- 8 Using special threaded tool (9), engage two or three threads on image intensifier (8) and pull straight back. Disengage special threaded tool from image intensifier.

2-7. ELBOW ASSEMBLY—MAINTENANCE INSTRUCTIONS. (cont)

DISASSEMBLY (cont)

- 9 Remove pneumatic valve cap (10), from purging valve stem (11) and then from valve cap strap (12).
- 10 Remove valve core (13) from purging valve stem (11).
- 11 Remove purging valve stem (11) from elbow assembly (6).
- 12 Remove valve cap strap (12) from purging valve stem (11).
- 13 Remove two machine screws (14), two lockwashers (15), and periscope latch (16) from elbow assembly (6).

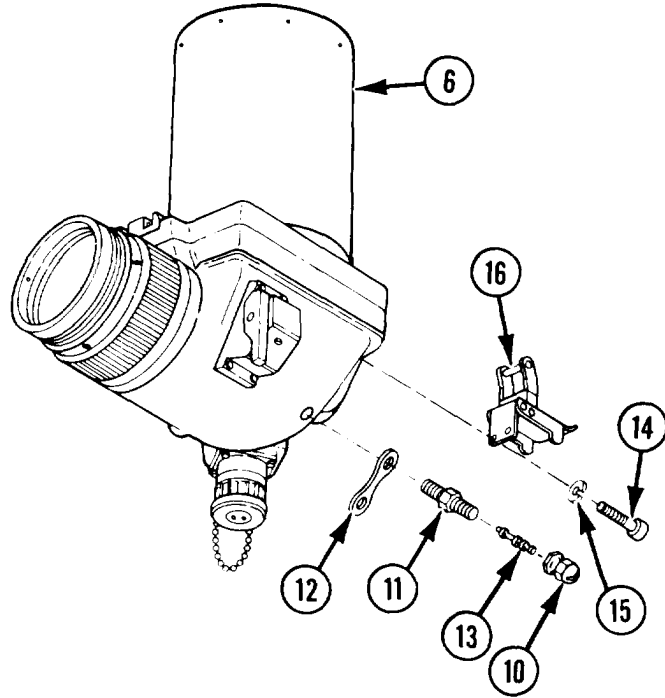

- 14 Remove four machine screws (17), four lockwashers (18), and deflection boresight knob assembly (19) from elbow assembly (6).
- 15 Remove preformed packing (20) and discard.
- 16 Remove four machine screws (21), four lockwashers (22), and elevation boresight knob assembly (23) from elbow assembly (6).
- 17 Remove preformed packing (24) and discard.
- 18 Remove six machine screws (25) and six lockwashers (26).
- 19 Remove cover assembly (27); remove assembled lampholder plug (28) from cover assembly.

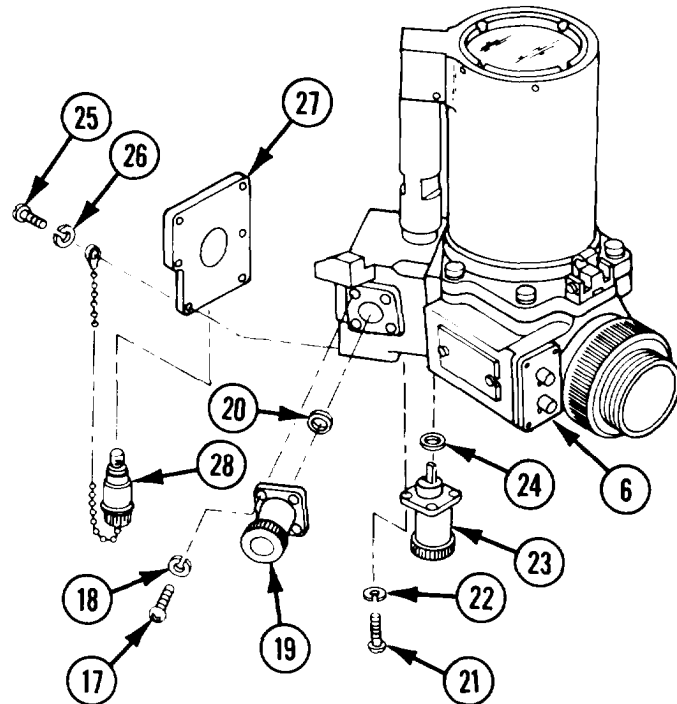

- 20 Remove four machine screws (29) and spring pin (30), only if necessary for replacement.

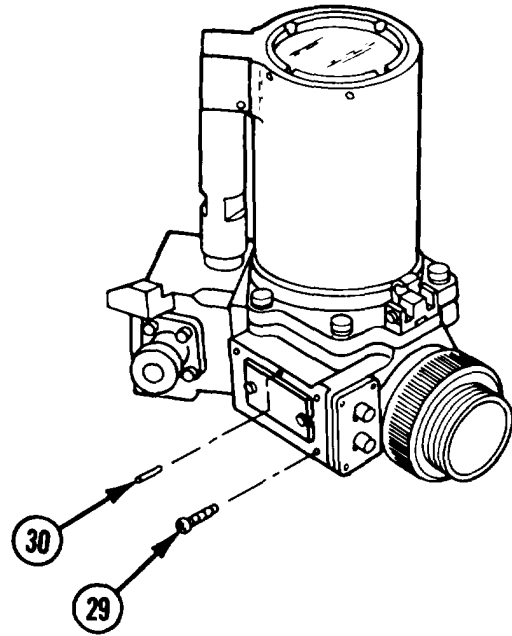

INSPECTION/CLEANING/REPAIR

- 1 Inspect optical components for chips, cracks, or damage that may interfere with operation of the tank periscope.
- 2 Check threaded components for damaged threads.
- 3 Check general condition of image intensifier.
- 4 Check that valve core is free of corrosion.
- 5 Inspect valve cap strap for tears.
- 6 Clean all traces of sealing compound from purging valve stem hole.
- 7 Clean optical surfaces in accordance with TM 9-254.
- 8 Replace any damaged, broken, or missing parts. See TM 9-1240-379-34P.
- 9 The eyepiece assembly is a repairable assembly. Refer to page 2-47.

2-7. ELBOW ASSEMBLY-MAINTENANCE INSTRUCTIONS. (cont)

REASSEMBLY

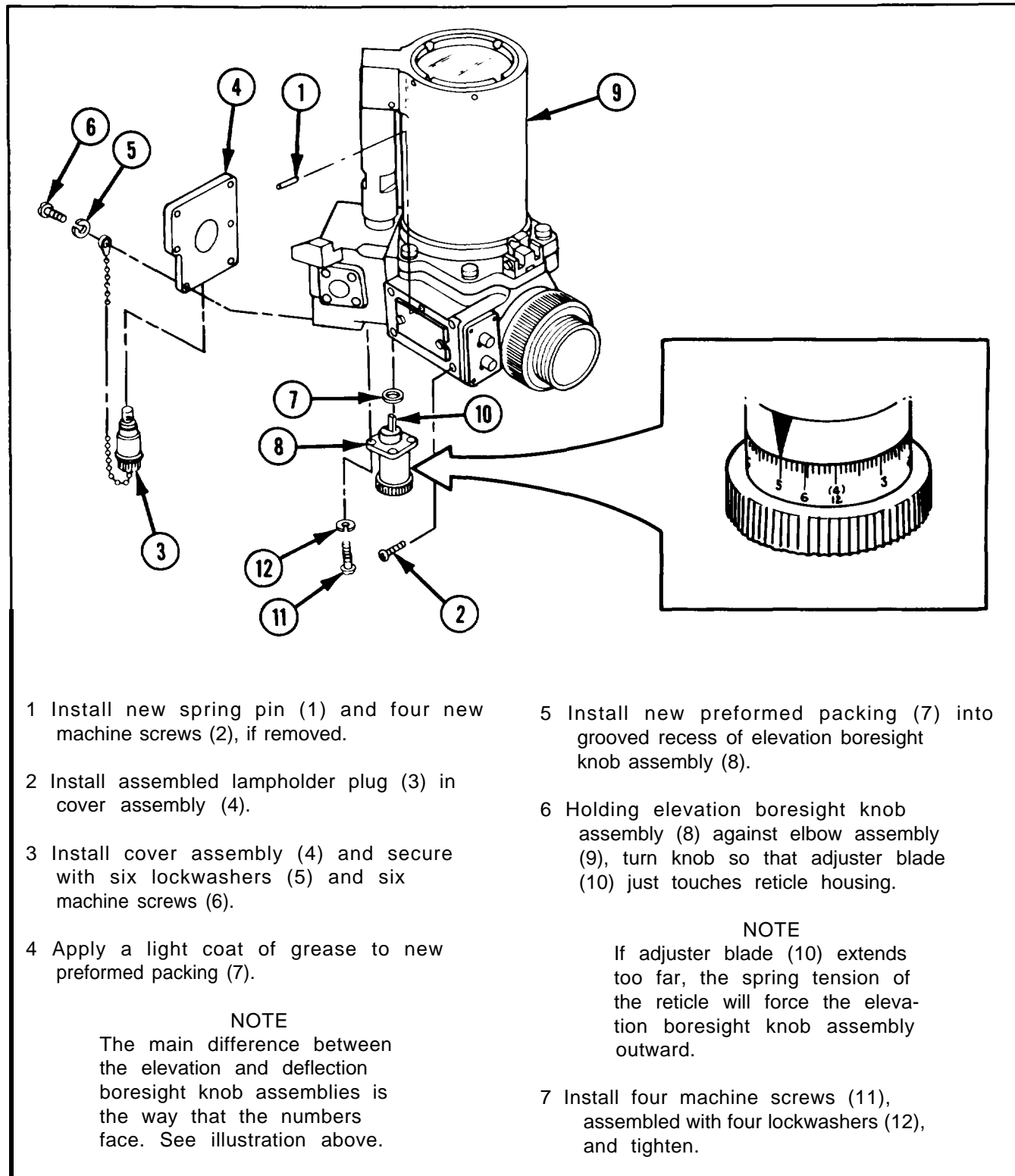

8 Adjust elevation boresight knob assembly (8):

- a. Remove screw (13) and spring (14).
- b. Remove knob (15) with scale attached. Do not remove scale.
- c. Set stop (16) against right-hand side of pin (17) in clutch (18).
- d. Install knob (15) so that pin is as close as possible against left-hand side of stop (16).
- e. Install spring (14) and screw (13); tighten screw (13).
- f. Turn knob (15) clockwise to its limit. Loosen screw (13) and rotate diopter scale to read +4.0. Tighten screw (13).
- g. Turn knob (15) counterclockwise to its limit. The diopter scale should read -4.0. If it does not read -4.0,

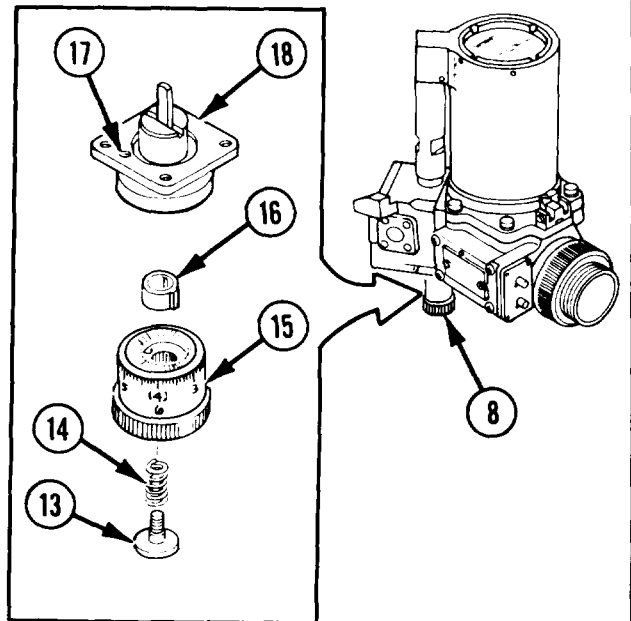

loosen screw (13) and turn diopter scale so that 0 is midpoint of the knob rotation. Tighten screw (13).

- 9 Apply a light coat of grease to new preformed packing (19).
- 10 Install new preformed packing (19) into grooved recess of deflection boresight knob assembly (20).
- 11 Holding deflection boresight knob assembly (20) against elbow assembly (9), turn knob so that adjuster blade (21) just touches reticle housing.

NOTE

If adjuster blade (21) extends too far, the spring tension of the reticle will force the deflection knob assembly outward.

- 12 Install four machine screws (22), assembled with four lockwashers (23), and tighten.

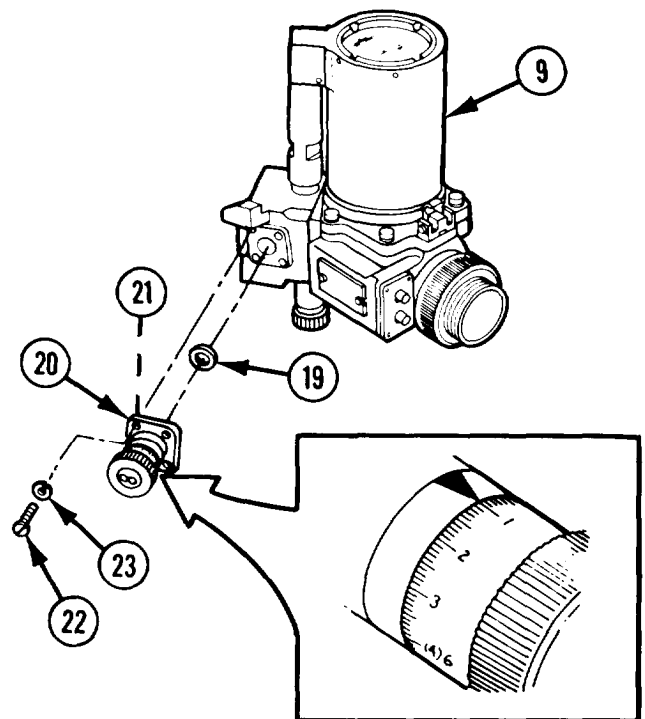

2-7. ELBOW ASSEMBLY-MAINTENANCE INSTRUCTIONS. (cont)

REASSEMBLY (cont)

- 13 Adjust deflection boresight knob assembly (20):
 - a. Remove screw (24) and spring (25).
 - b. Remove knob (26) with scale attached. Do not remove scale.
 - c. Set stop (27) against right-hand side of pin (28) in clutch (29).
 - d. Install knob (26) so that pin is as close as possible against left-hand side of stop (27).
 - e. Install spring (25) and screw (24); tighten screw (24).
 - f. Turn knob (26) clockwise to its limit. Loosen screw (24) and rotate diopter scale to read +4.0. Tighten screw (24).
 - g. Turn knob (26) counterclockwise to its limit. The diopter scale should read -4.0. If it does not read -4.0,

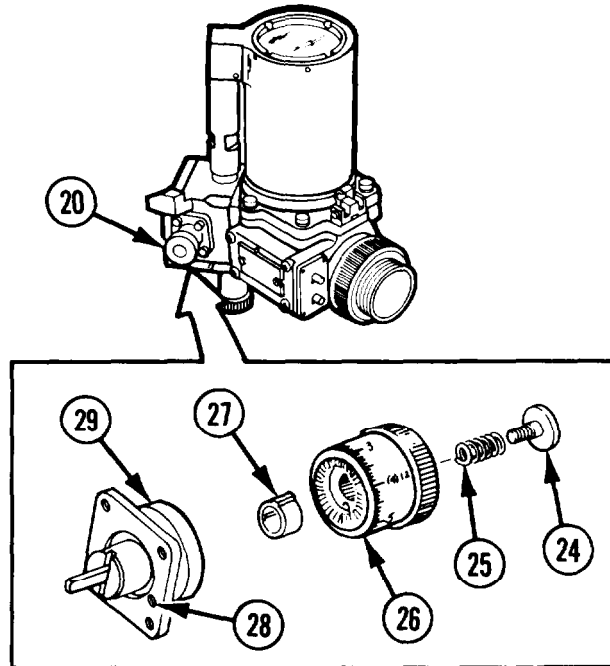

loosen screw (24) and turn diopter scale so that 0 is midpoint of the knob rotation. Tighten screw (24).

- 14 Install periscope latch (30), two lockwashers (31), and two machine screws (32).
- 15 Assemble valve cap strap (33) to tapered thread end of purging valve stem (34).
- 16 Apply sealing compound to tapered thread end of purging valve stem (34).
- 17 Install purging valve stem (34) in valve assembly (9) and tighten.
- 18 Install valve core (35) in purging valve stem (34).
- 19 Assemble pneumatic valve cap (36) to loose end of valve cap strap (33) and install on purging valve stem (34).

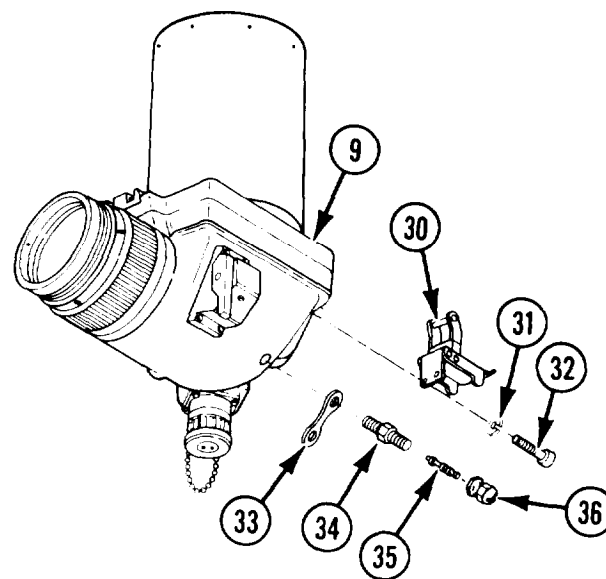

CAUTION

Damage may result if image intensifier is exposed to bright sunlight or high intensity artificial light.

- 20 Install image intensifier (37) in elbow assembly (9).
- 21 Install new preformed packing (38) into threaded adapter (39).
- 22 Install threaded adapter (39) on elbow assembly (9) and tighten. Secure by tightening three setscrews (40).
- 23 Install eyepiece assembly (41) on threaded adapter (39). Tighten eyepiece assembly (41) and secure with two setscrews (42).
- 24 Install optical eyeshield (43) onto eyepiece assembly (41).
- 25 After maintenance has been completed, purge and charge tank periscope in accordance with TM 750-116.

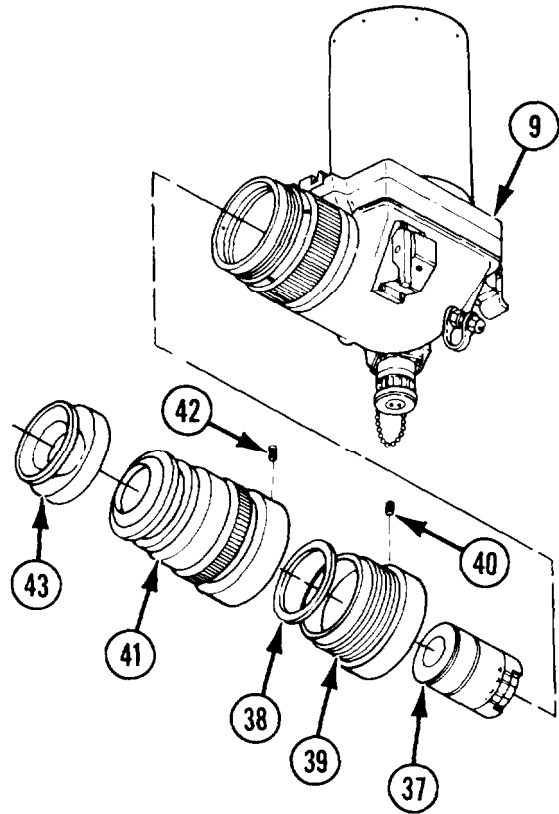

2-8. PRISM CELL-MAINTENANCE INSTRUCTIONS.

THIS TASK COVERS:

- | | | |
|----------------|-------------------------------|---------------|
| a. Disassembly | b. Inspection/cleaning/repair | c. Reassembly |
|----------------|-------------------------------|---------------|

INITIAL SETUP

Applicable Configurations
M32E1 and M32CE1 tank periscopes

Tools and Special Tools
Helicoil insert and tool kit (4131-04-1)
Instrument and fire control shop equipment (SC 4931-95-CL-A07)
Instrument and fire control system repair shop equipment (SC 4931-95-CL-A09)

Materials/Parts

Artist's brush (item 3, app B)
Ethyl alcohol (item 9, app B)
Lens paper (item 14, app B)

References
TM 9-254
TM 9-1240-379-34P
TM 750-116

Equipment Conditions
Page 2-8 Elbow assembly removed from tank periscope

2-8. PRISM CELL-MAINTENANCE INSTRUCTIONS. (cont)

DISASSEMBLY

WARNING

Detent plunger is under spring tension. Be careful when removing or injury may result.

- 1 Remove retaining ring (1) from detent plunger (2) while pressing a screwdriver blade against detent plunger to release spring tension. Remove detent plunger and helical compression spring (3).
- 2 Remove two machine screws (4) and machine key (5), assembled with catch strike (6), from elbow assembly (7).
- 3 Remove machine screw (8) and separate catch strike (6) from machine key (5).
- 4 Remove two screw thread inserts (9), only if necessary for replacement. Refer to TM 9-254.

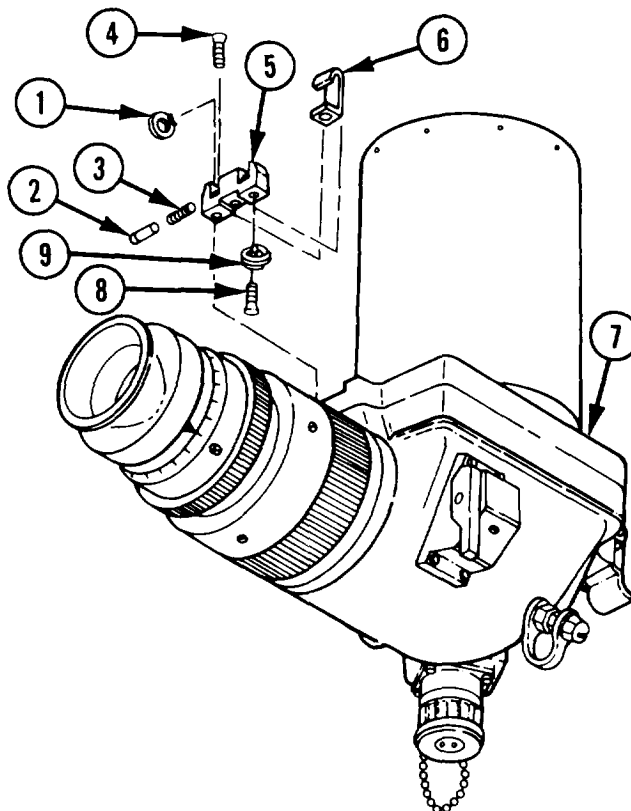

INSPECTION/CLEANING/REPAIR

- 1 Inspect all parts for wear or deterioration.
- 2 Check machine screws for worn or damaged threads. Clean dirt and grime from all threads.
- 3 Inspect helical compression spring for breaks.
- 4 Clean optical surfaces in accordance with TM 9-254.
- 5 Replace any damaged, broken, or missing parts. See TM 9-1240-379-34P.

REASSEMBLY

- 1 Install two new screw thread inserts (1), if old ones were removed. Refer to TM 9-254.
- 2 Assemble machine key (2) to catch strike (3) and secure with machine screw (4).
- 3 Position assembled machine key and catch strike on elbow assembly (5) and secure with two machine screws (6).
- 4 Install helical compression spring (7) and detent plunger (8) in machine key (2).
- 5 Install retaining ring (9).
- 6 After maintenance has been completed, purge and charge tank periscope in accordance with TM 750-116.

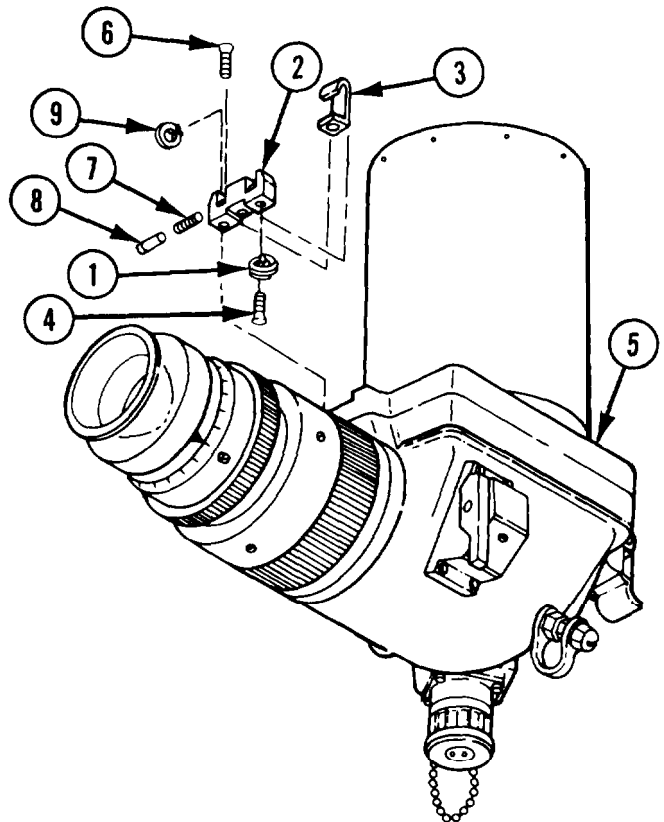

2-9. EYEPIECE ASSEMBLY—MAINTENANCE INSTRUCTIONS.

THIS TASK COVERS:

- | | | |
|----------------|-------------------------------|---------------|
| a. Disassembly | b. Inspection/cleaning/repair | c. Reassembly |
|----------------|-------------------------------|---------------|

INITIAL SETUP

Applicable Configurations
M32E1 and M32CE1 tank periscopes

Tools and Special Tools
Instrument and fire control shop equipment (SC 4931-95-CL-A07)
Instrument and fire control system repair shop equipment (SC 4931-95-CL-A09)

References
TM 9-254
TM 9-1240-379-34P
TM 750-116

Equipment Conditions
Page 2-39 Eyepiece assembly removed from elbow assembly

2-9. EYEPIECE ASSEMBLY—MAINTENANCE INSTRUCTIONS. (cont)

DISASSEMBLY

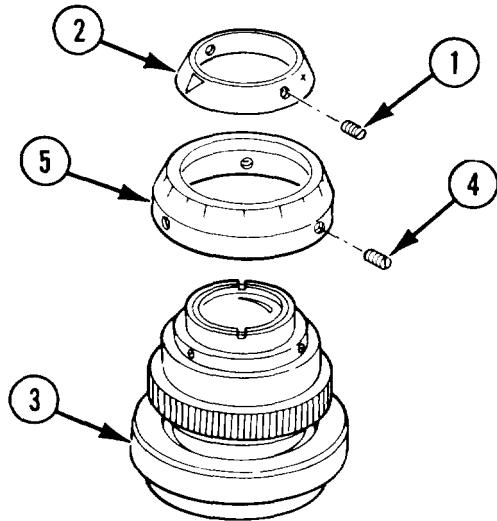

- 1 Remove two setscrews (1) and index (2) from eyepiece assembly (3).
- 2 Remove three setscrews (4) and diopter scale (5) from eyepiece assembly (3).

INSPECTION/CLEANING/REPAIR

- 1 Clean optical surface in accordance with TM 9-254.
- 2 Replace any damaged, broken, or missing parts in accordance with TM 9-1240-379-34P.

REASSEMBLY

- 1 Install diopter scale (1) on eyepiece assembly (2) and secure with three setscrews (3).
- 2 Install index (4) and two setscrews (5) into eyepiece assembly (2).
- 3 After maintenance has been completed, purge and charge in accordance with TM 750-116.

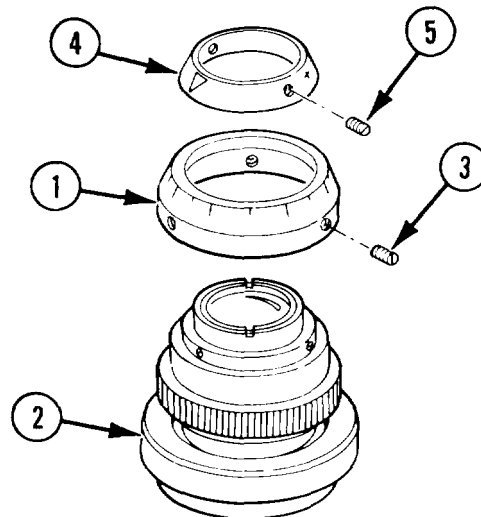

Section III. PREPARATION FOR STORAGE OR SHIPMENT

2-10. PREPARATION FOR PACKAGING

- a. Clean all surfaces in accordance with MIL-P-116.
- b. Cover eyepiece assembly with a protective cap (item 5, app B). Cover all other optics with four pieces of lens paper (item 14, app B) and secure with tape (item 20, app B).
- c. Position a mailing tube (item 22, app B) over the eyepiece assembly containing the electron tube; secure with tape (item 20, app B) as follows:
 - (1) Wrap one piece around knurled ring and cap (adjacent to mailing tube) so that half the width of the tape is on the knurled ring and the other half is on the mailing tube.
 - (2) Cross two pieces at 90 degrees over the center of the open end of the mailing tube and extend down the mailing tube and over the full width of the knurled ring.
- d. Secure a shipping tag (item 19, app B) to the mailing tube with the following information: CAUTION-PAPER MAILING TUBE SHALL NOT BE REMOVED UNTIL AFTER INSTALLING TANK PERISCOPE INTO THE MOUNT.
- e. Position a piece of flat steel banding (3/8 x 1-1/2 x 0.23) conforming to Type 1, Class B of QQ-S-781 between the wedge (coupling arm assembly) and the stop to prevent movement. Wrap a piece of tape (item 20, app B) around wedge and steel banding to secure.
- f. Secure a shipping tag (item 19, app B) to the wedge with the following information:

CAUTION-FLAT STEEL SPRING IMMOBILIZING WEDGE (COUPLING ARM ASSEMBLY) SHALL NOT BE REMOVED UNTIL PRIOR TO INSTALLING THE TANK PERISCOPE INTO THE MOUNT.

2-11. PACKAGING SEQUENCE

- a. Wrap tank periscope with laminated and creped wrapping paper (item 15, app B) and secure with tape (item 20, app B).
 - b. Overwrap with wrapping and cushioning paperboard (item 13, app B) and secure with tape (item 20, app B).
 - c. Place item into a plastic bag (item 2, app B). Exhaust entrapped air prior to heat sealing.
 - d. Using cushioning material (item 7, app B), line a shipping box (item 4, app B) as follows:
 - (1) two pieces each 30 x 21 -3/8 x 4 in. (76.2 x 54.29 x 10.16 cm) for sides
 - (2) two pieces each 14 x 21 -3/8 x 4 in. (35.56 x 54.29 x 10.16 cm) for ends
 - (3) two pieces each 22 x 14 x 4 in. (55.88 x 35.56 x 10.16 cm) for top and bottom
- NOTE**
- The bagged tank periscope will fit snugly in the cushioned shipping box when the shipping box is closed.
- e. Close shipping box and secure with adhesive tape (item 21, app B).

Section IV. PRE-EMBARKATION INSPECTION OF MATERIEL IN UNITS ALERTED FOR OVERSEAS MOVEMENT

2-12. GENERAL.

Pre-embarkation is performed on materiel in the hands of troops alerted for overseas duty to ensure that such materiel will not become unserviceable or worn out in a relatively short time. It prescribes a higher percentage of remaining usable life in serviceable materiel to meet a specific need beyond minimum serviceability.

2-13. GENERAL INSPECTION.

a. Examine tank periscope to ensure that all component parts are present. Check particularly for missing pins, screws, and other attaching hardware.

b. Check exterior for damaged, cracked, or dented surfaces, bent or broken parts, moisture or corrosion, and other evidence of misuse that might indicate a need for repair.

c. Inspect all sealed areas to assure that sealing is still intact.

d. Inspect nameplates to ensure that all numbering and lettering is clearly defined and easily read.

e. Inspect diopter scales to ensure that they are clearly defined and easily read.

f. Inspect for bare spots or damaged finish which would expose metal surfaces and lead to corrosion.

g. Test alinement and looseness of body assemblies by checking periscope latches, strikes, plungers, and brackets.

h. Check that deflection and elevation boresight knob assemblies are firmly seated against clutches.

i. After recording setting of each boresight knob assembly, disengage knob from clutch and rotate it through its complete range. Operation must be smooth throughout. When finished, reset knob to position recorded before disengaging.

2-14. INSPECTION OF OPTICAL ELEMENTS.

a. Lenses, reticles, and windows must be free from scratches, pits, dirt, smears, digs, fractures, and chips that may interfere with or affect the optical performance of the tank periscope.

b. Any breakdown or excessive discoloration of cement between elements of compound lenses that affects optical performance in the field is cause for rejection of the instrument.

c. When looking through the tank periscope, there must be no evidence of moisture or fungus growth.

d. When sighting through the tank periscope, the image and reticle must be clearly defined. There must be no indication of parallax or image tilt as defined in TM 9-258.

NOTE

Level tank periscope and make the following checks looking through elbow assembly/infrared body assembly and daylight body assembly.

(1) Parallax. Look at a target with sharp horizontal and vertical lines at a distance of 1200 meters (3937 feet); parallax must not exceed the thickness of one reticle line.

(2) Parallelism. Look at a target with sharp horizontal and vertical lines at a distance of 1200 meters (3937 feet). The lines on the target should be parallel with the lines on the reticle image within 2 mils of arc.

NOTE

This is with Periscope installed in tank and inspected at the time of synchronization and alinement.

2-15. INSPECTION OF ELECTRICAL COMPONENTS.

a. Visually inspect electrical and power materiel for evidence of circuit faults or possible sources of trouble as indicated by the conditions listed below:

- (1) Burned or carbonized insulation.
- (2) High-voltage arcs or short circuits.
- (3) Improperly soldered connections.

(4) Electrical contacts not making connection.

(5) Burned out incandescent lamp.

b. Check image intensifier system for evidence of the following malfunctions:

- (1) Visible flicker.
- (2) Image movement.
- (3) Audible sparking.

CHAPTER 3 GENERAL SUPPORT MAINTENANCE INSTRUCTIONS

Section I. TROUBLESHOOTING

3-1. TROUBLESHOOTING INFORMATION.

a. The symptom index can be used as a quick guide to troubleshooting. Common malfunctions are listed in alphabetical order with a page number reference to the troubleshooting table where a test or inspection and corrective action are provided.

manual cannot list all malfunctions that may occur, nor all tests or inspections and corrective actions. If the malfunction is not listed, or if the malfunction still exists after all listed corrective actions have been performed, notify your supervisor.

b. Table 3-1 lists the malfunction, the test or inspection indicating the malfunction, and the corrective action needed. This

SYMPTOM INDEX

ELBOW ASSEMBLY	Troubleshooting Procedure (Page No.)
No night channel image, low brilliance of night image, or night image flickers or moves.	3-2
Poor or no illumination of night reticle	3-1

Table 3-1. TROUBLESHOOTING

MALFUNCTION
TEST OR INSPECTION
CORRECTIVE ACTION
ELBOW ASSEMBLY
<p>1. POOR OR NO ILLUMINATION OF NIGHT RETICLE.</p> <p style="padding-left: 40px;">With objective lens covered to simulate darkness, turn shutter assembly switch ON (reset if needed) and operate TUBE control knob.</p> <ul style="list-style-type: none"> a. If image intensifier lights, replace RETICLE control knob (page 3-19). b. If image intensifier does not light, replace regulator assembly (page 3-15). c. If malfunction still is not corrected, replace elbow assembly (page 2-8).

3-1. TROUBLESHOOTING INFORMATION. (cont)

Table 3-1. TROUBLESHOOTING (cont)

MALFUNCTION	TEST OR INSPECTION	CORRECTIVE ACTION
ELBOW ASSEMBLY (cont)		
2. NO NIGHT CHANNEL IMAGE, LOW BRILLIANCE OF NIGHT IMAGE, OR NIGHT IMAGE FLICKERS OR MOVES.		
Step 1. Check that regulator assembly is not defective.		
Replace defective regulator assembly (page 3-15).		
Step 2. Check continuity of TUBE control knob and TUBE variable resistor (refer to wiring diagram).		
<ul style="list-style-type: none"> a. If continuity check fails, replace TUBE control knob (page 3-19), TUBE variable resistor (page 3-19), or both, as required. b. If malfunction is not corrected, replace elbow assembly (page 2-8). 		

3-2. HEAD ASSEMBLY—MAINTENANCE INSTRUCTIONS. (cont)

INSPECTION/CLEANING/REPAIR

- 1 Inspect all parts for deterioration.
- 2 Check machine screws for worn or damaged threads.
- 3 Make sure replacement optical instrument window is free of chips, cracks, scratches, and discoloration.
- 4 Remove old sealing compound from recess in housing and from strips used to retain optical instrument window using dry cleaning solvent.
- 5 If original optical instrument window has shattered, make sure that interior of head assembly is free of glass chips and particles.
- 6 Replace any damaged, broken, or missing parts. See TM 9-1240-379-34P.

WARNING

Dry cleaning solvent is flammable and should not be used near open flame. It has a drying effect on the skin. Use gloves, as they may prevent cracks in the skin and, in the case of some individuals, mild irritation or inflammation. Use dry cleaning solvent in well ventilated areas.

REASSEMBLY

- 1 Position new optical instrument window (1) in housing of head assembly (2) and apply sealing compound in beveled recess around edge of optical instrument window.
- 2 Secure optical instrument window (1) with strip (3) at bottom using five machine screws (4) and strip (5) at top using five machine screws (6).
- 3 After optical instrument window has been installed in head assembly, purge and charge in accordance with TM 750-116.

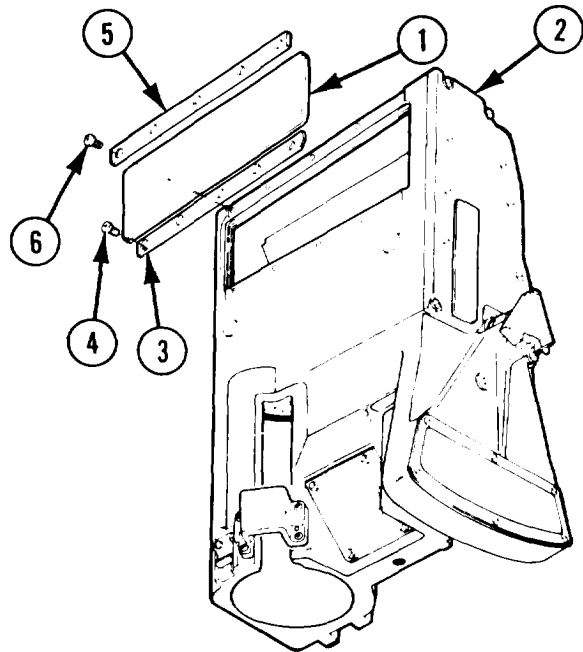

3-3. DAYLIGHT BODY ASSEMBLY—MAINTENANCE INSTRUCTIONS (cont)

INSPECTION/REPAIR

Replace any damaged, missing, or broken parts. See TM 9-1240-379-34P.

REASSEMBLY

- 1 Fabricate replacement electrical wire (fig. C-1, app C).
- 2 Install electrical wire (1) through contact opening. Feed electrical wire (1) through daylight body assembly housing by gently pushing a probe through wire passage hole (2).
- 3 Pull loose end of electrical wire (1) from opening for incandescent lamp receptacle far enough to permit making solder connection.

NOTE

When installing connector, make sure notch on connector is correctly positioned in groove to allow proper grounding.

- 4 Using solder, install electrical ring (3) on connector (4).
- 5 Using solder, attach electrical wire to opposite contact prong and install connector (4) in daylight body assembly (5).
- 6 Using tubular spanner wrench, install externally threaded ring (6).
- 7 Install incandescent lamp (7), gasket (8), and lampholder (9) in daylight body assembly (5).
- 8 Using solder, attach end of electrical wire (1) to contact (10).

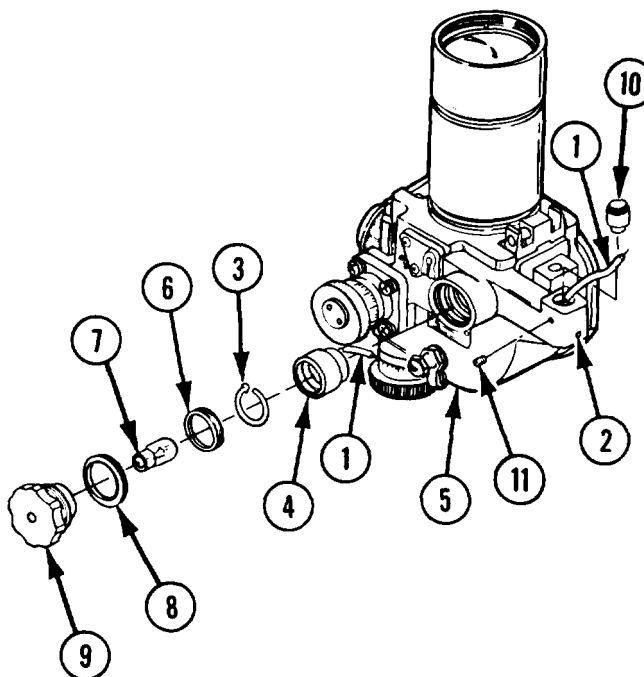

- 9 Coil excess electrical wire to allow contact to be installed in daylight body assembly (5); secure contact with setscrew (11) and apply sealing compound to setscrew hole and wire passage hole (2).
- 10 After maintenance has been completed, purge and charge in accordance with TM 750-116.

3-4. OPTICAL CELL ASSEMBLY-MAINTENANCE INSTRUCTIONS. (cont)

INSPECTION/CLEANING/REPAIR

- 1 Clean optical surfaces in accordance with TM 9-254.
- 2 Replace any damaged, broken, or missing parts. See TM 9-1240-379-34P.

REASSEMBLY

- 1 Apply a light coat of grease to new preformed packing (1) and install in ring groove inside adapter (2).
- 2 Install optical element cell (3) on adapter (2), aligning slot in optical element cell with stop hole in adapter.
- 3 Install stop (4) in adapter (2).
- 4 Install optical retaining ring (5) on adapter (2) and turn optical retaining ring clockwise until it seats against adapter. Do not tighten.
- 5 Install round plain nut (6) on optical retaining ring (5) and hand tighten.

CAUTION

Make sure that setscrew securing round plain nut is below outside surface of round plain nut to prevent damage to diopter scale.

- 6 Apply sealing compound to threads of setscrew (7) and install in round plain nut (6). Tighten setscrew.
- 7 Install diopter scale (8) on optical element cell (3).
- 8 Adjust diopter scale (8) according to instructions in paragraph 3-10c(2).

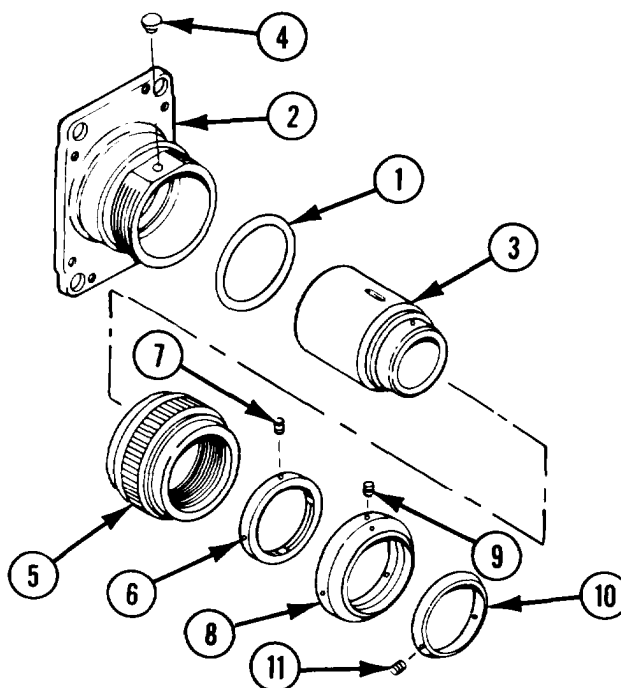

- 9 Apply sealing compound to three setscrews (9) and install in diopter scale (8); tighten setscrews.
- 10 Install dial pointer (10).
- 11 Apply sealing compound to two setscrews (11) and install in dial pointer (10); tighten setscrews.
- 12 After maintenance has been completed, purge and charge in accordance with TM 750-116.

3-5. INFRARED BODY ASSEMBLY – MAINTENANCE INSTRUCTIONS. (cont)

DISASSEMBLY (cont)

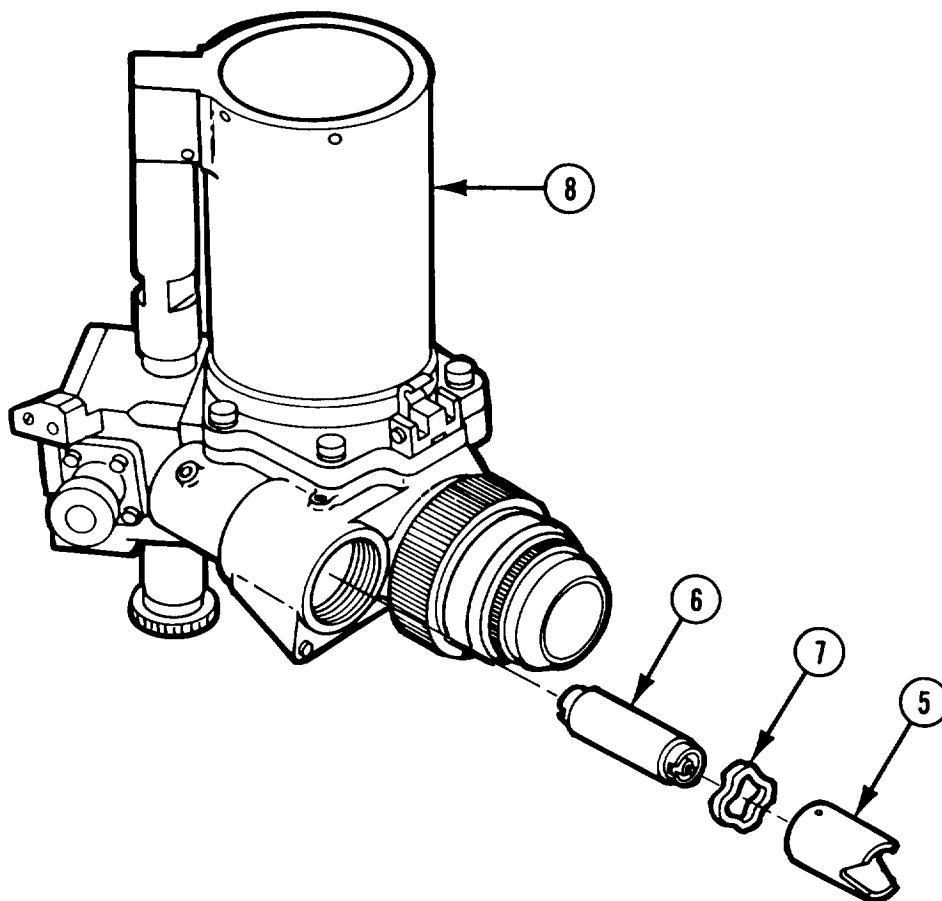

NOTE

The solid power supply has two bayonet-type slots which, when assembled with the spring tension washer and pinned sleeve, are interlocked and will be removed as an assembly.

- 5 Rotate pinned sleeve (5) counterclockwise as far as possible, disengaging output end of solid power supply (6) from interlocking pins of connector.

NOTE

Parts in step 6 are to be removed as an assembly.

- 6 Remove pinned sleeve (5), spring tension washer (7), and solid power supply (6) from infrared body assembly (8).
- 7 Remove solid power supply (6) from pinned sleeve (5). Remove spring tension washer (7) and discard.

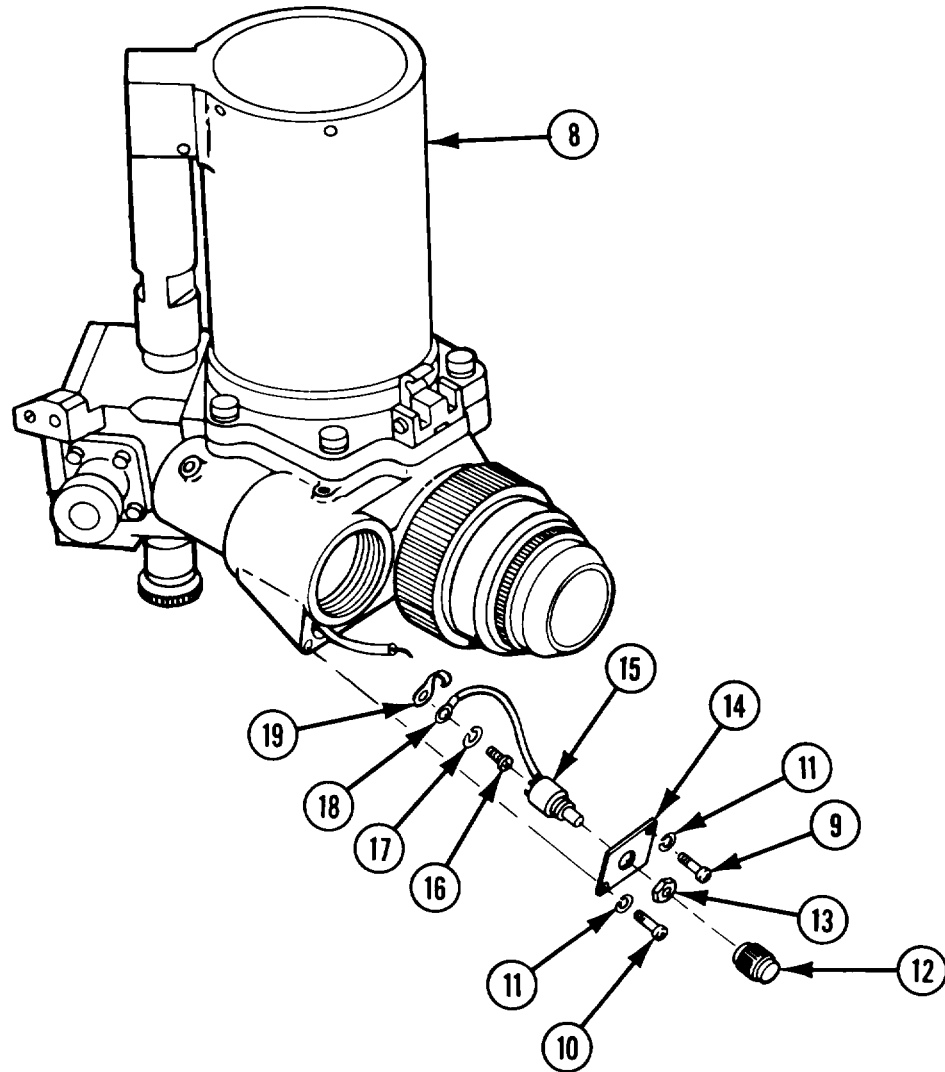

8 Remove three machine screws (9), machine screw (10), four lockwashers (11), and knob (12) from infrared body assembly (8).

9 Remove hex nut (13) and plate (14).

10 Remove rotary switch (15).

11 Remove insulation from terminal connections.

12 Unsolder electrical leads from terminals of rotary switch (15), identifying each one as removed (refer to wiring diagram on page 3-13).

13 Remove machine screw (16), lockwasher (17), terminal lug (18), and spring tension clip (19).

14 Unsolder terminal lug (18) from connecting wire.

3-5. INFRARED BODY ASSEMBLY—MAINTENANCE INSTRUCTIONS. (cont)

DISASSEMBLY (cont)

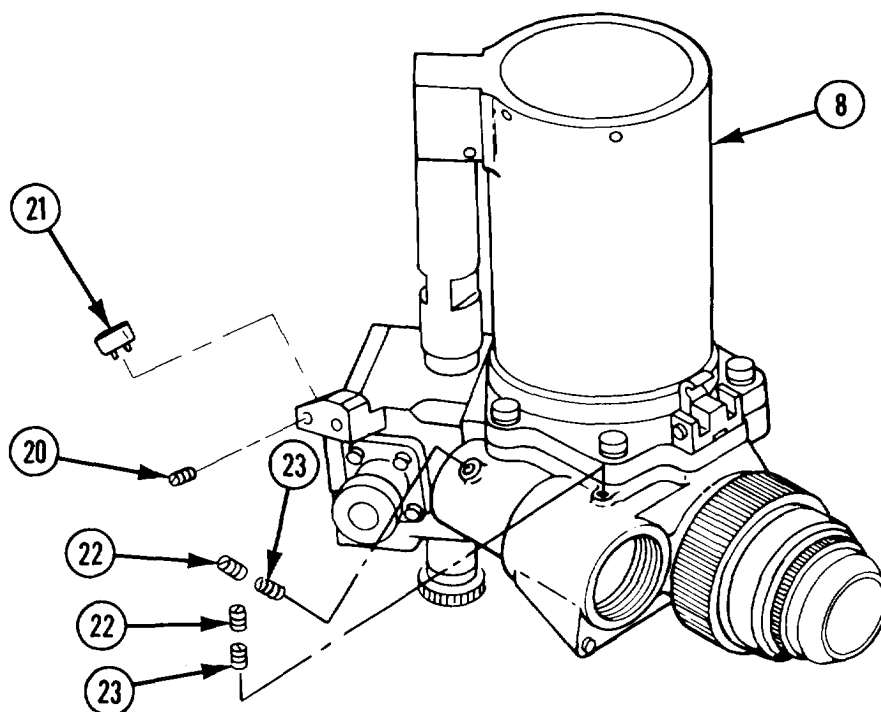

NOTE

Remove setscrew (20) and contact (21) only if contact (21) needs replacement.

- 15 Remove setscrew (20).
- 16 Remove contact (21) from infrared body assembly (8) with wire leads attached.
- 17 Unsolder wire leads and remove contact (21).

NOTE

Remove two setscrews (22) and two setscrews (23) only if necessary for replacement.

- 18 Remove two setscrews (22) and two setscrews (23).

INSPECTION/REPAIR

Replace any damaged, broken, or missing parts. See TM 9-1240-379-34P.

REASSEMBLY

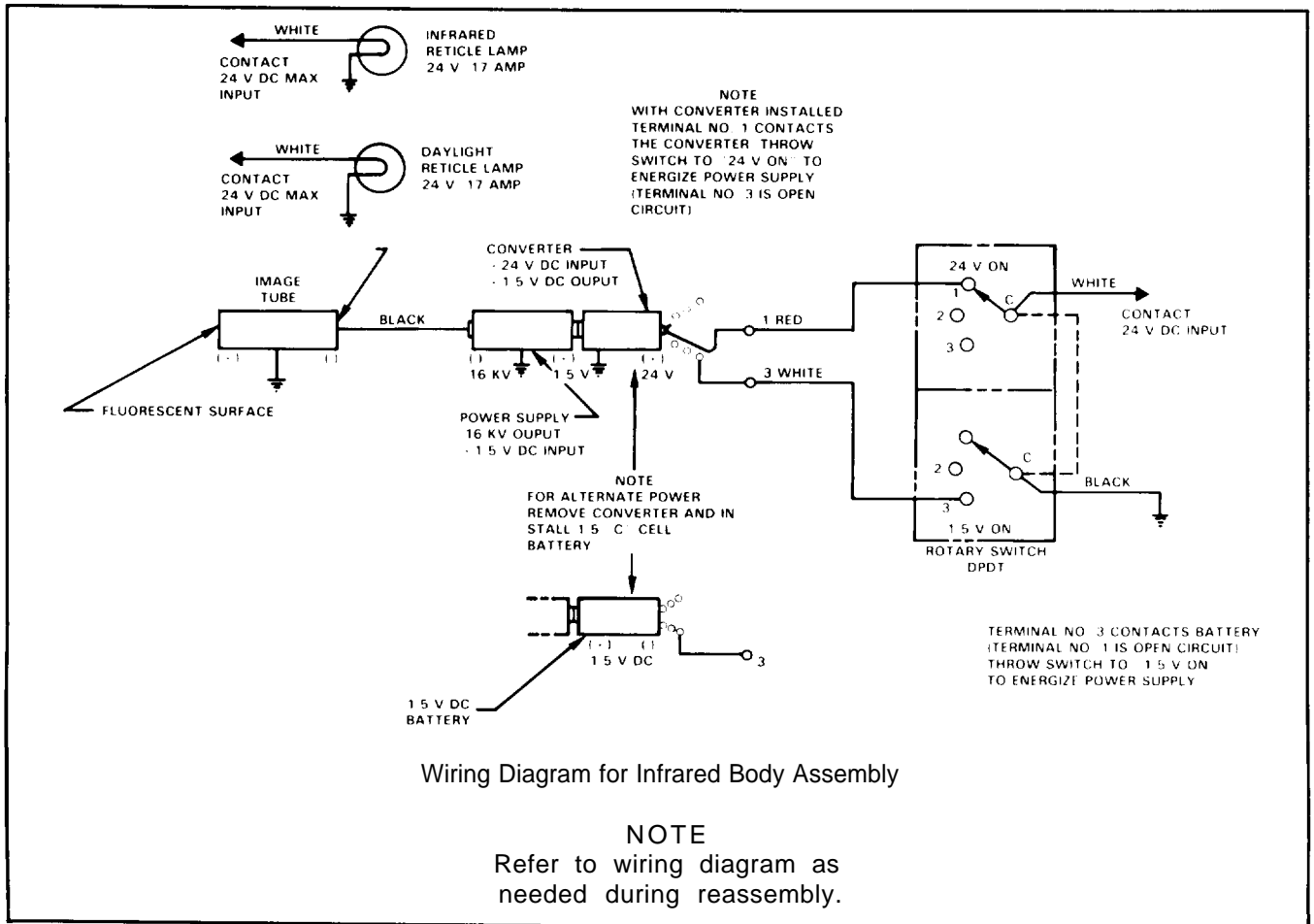

- 1 If removed, install two setscrews (1) and two setscrews (2) in infrared body assembly (3).
- 2 Attach wire leads to contact (4) using solder; install contact (4) in infrared body assembly (3).
- 3 Apply sealing compound to threads of setscrew (5); install setscrew and tighten.

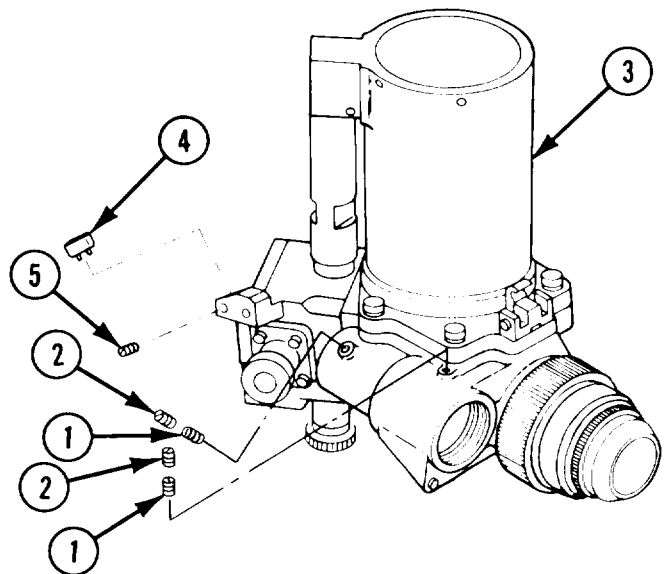

3-5. INFRARED BODY ASSEMBLY—MAINTENANCE INSTRUCTIONS. (cont)

REASSEMBLY (cont)

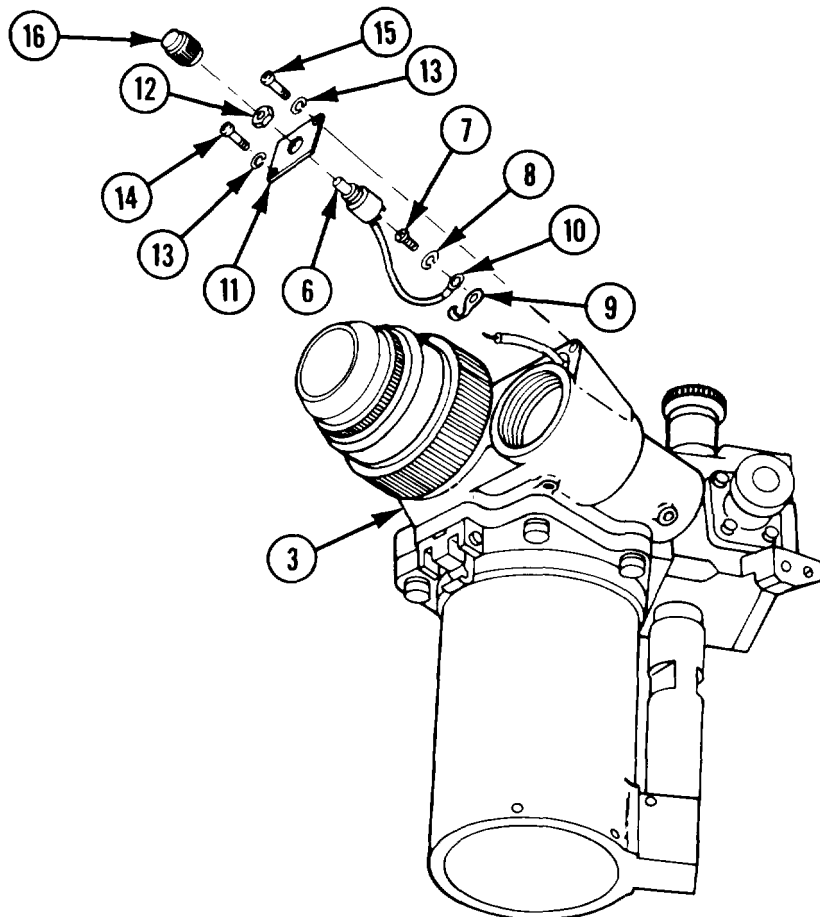

4 Fabricate replacement electrical wire (fig. C-5, app C).

5 Fabricate insulation sleeving (fig. C-2, app C).

NOTE

Turn infrared body assembly (3) upside down for steps 6 thru 18.

6 Solder wire lead to terminal of rotary switch (6). Position insulation sleeving over soldered connections and heat to shrink.

7 Assemble machine screw (7), lockwasher (8), spring tension clip (9), and terminal lug (10); solder connecting

wire to terminal lug (10), install, and tighten. Refer to wiring diagram on page 3-13.

8 Assemble plate (11) on rotary switch (6).

9 Install hex nut (12) on rotary switch (6) and tighten.

10 Position rotary switch (6) and plate (11) on infrared body assembly (3) and install four lockwashers (13), three machine screws (14), and machine screw (15).

11 Install knob (16) on rotary switch (6) and tighten.

- 12 Assemble new spring tension washer (17) to input end of solid power supply (18).
- 13 Aline pins of pinned sleeve (19) to bayonet-type slots of solid power supply (18).
- 14 Compress spring tension washer (17) and rotate pinned sleeve (19) clockwise to secure.

NOTE

Make sure that spring tension clip (9) contacts solid power supply (18).

- 15 Install assembled components in infrared body assembly (3), alining bayonet-type slots with interlocking pins of connector; rotate clockwise to secure.
- 16 Install converter regulator (20) in pinned sleeve (19).
- 17 Assemble new gasket (21) to cap assembly (22).
- 18 Install cap assembly (22) in infrared body assembly (3) and tighten.

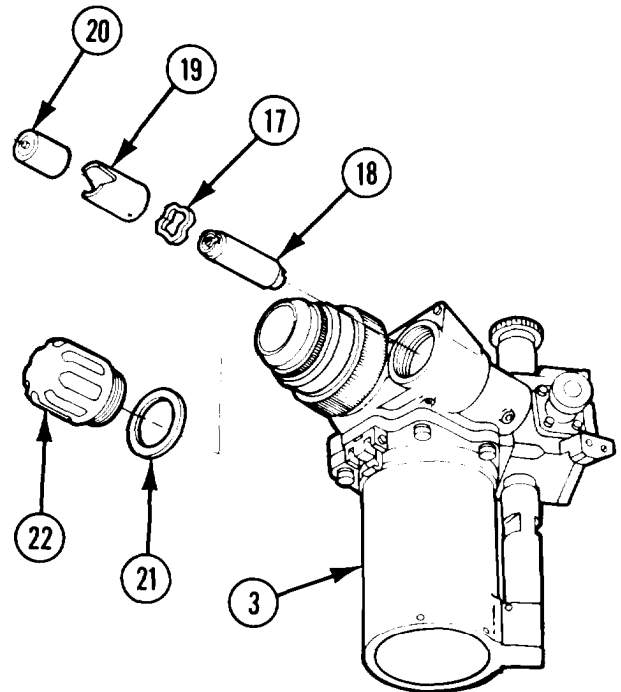

19 After maintenance has been completed, purge and charge in accordance with TM 750-116.

3-6. ELBOW ASSEMBLY-MAINTENANCE INSTRUCTIONS.

THIS TASK COVERS:

- | | | |
|----------------|----------------------|---------------|
| a. Disassembly | b. Inspection/repair | c. Reassembly |
|----------------|----------------------|---------------|

INITIAL SETUP

Applicable Configurations
M32E1 and M32CE1 tank periscope

Solder (item 18, app B)
White silicone adhesive (item 1, app B)

Tools and Special Tools
Instrument and fire control shop equipment (SC 4931-95-CL-A07)
Instrument and fire control system repair shop equipment (SC 4931-95-CL-A09)

References
TM 9-1240-379-34P
TM 750-116

Materials/Parts
Flat gasket (11733499)
Sealing compound (item 16, app B)

Equipment Conditions
Page 2-8 Elbow assembly removed from tank periscope

3-6. ELBOW ASSEMBLY—MAINTENANCE INSTRUCTIONS. (cont)

DISASSEMBLY

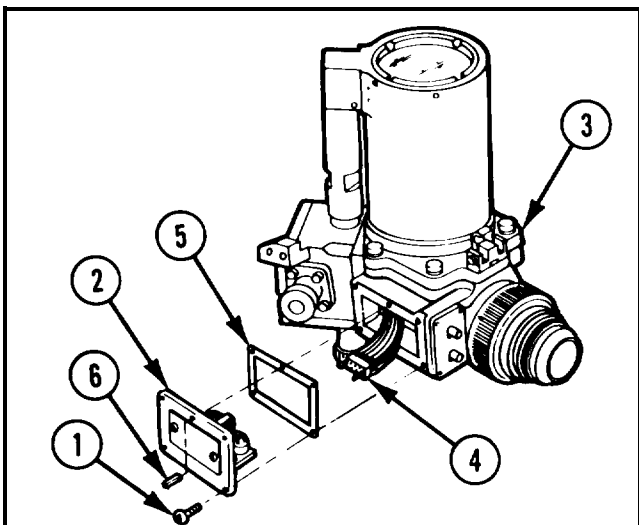

1 Remove four machine screws (1).

2 Pull out regulator assembly (2) from elbow assembly (3) and unplug electrical connector (4).

3 Remove flat gasket (5) and discard.

4 Remove spring pin (6) if loose or bent.

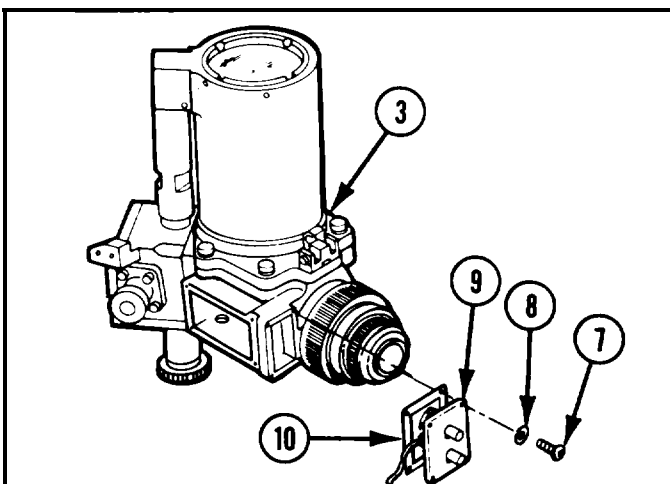

5 Remove four machine screws (7) and four lockwashers (8); pull out switch assembly (9) as far as possible without straining wires.

6 Label and unsolder six wires; remove switch assembly (9) from elbow assembly (3).

7 Remove gasket (10).

INSPECTION/REPAIR

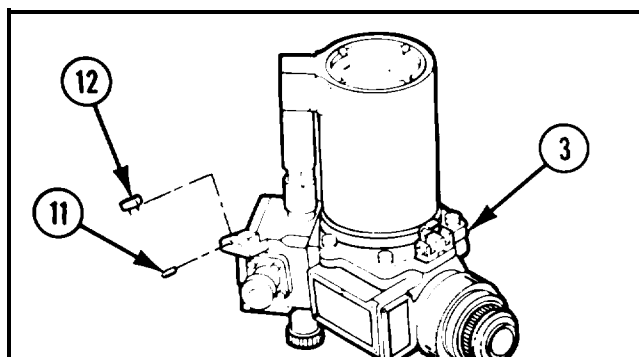

8 Remove setscrew (11) and pull contact (12) from elbow assembly (3) with wire leads attached.

9 Label and unsolder wire leads; remove contact (12).

1 Replace any missing, damaged, or broken parts. See TM 9-1240-379-34P.

2 The switch assembly is a repairable assembly. Refer to page 3-19.

REASSEMBLY

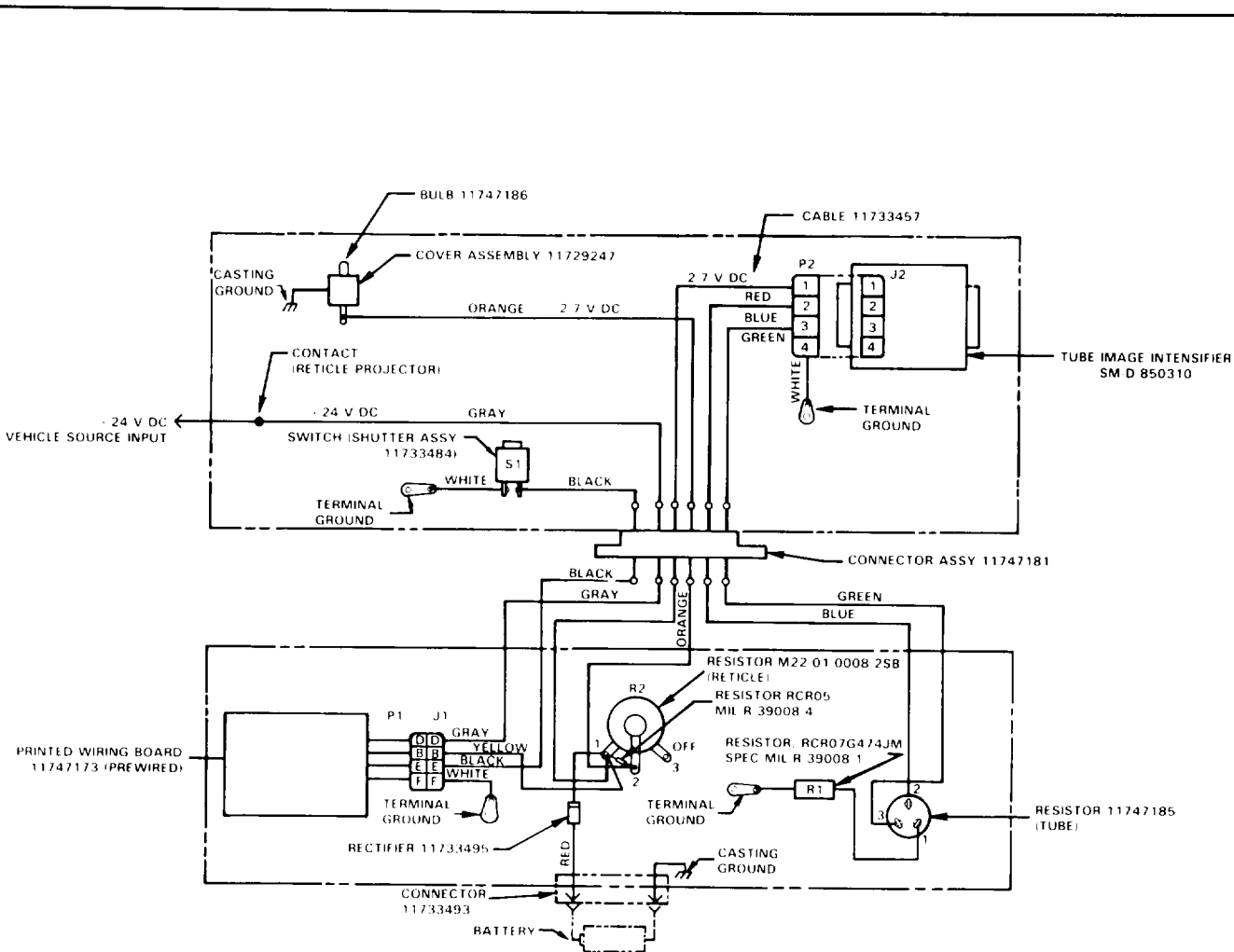

Wiring Diagram for Elbow Assembly

NOTE
Refer to wiring diagram as needed during reassembly.

3-6. ELBOW ASSEMBLY—MAINTENANCE INSTRUCTIONS. (cont)

REASSEMBLY (cont)

- 1 Attach wire leads to contact (1) using solder; install contact in elbow assembly (2).
- 2 Apply sealing compound to threads of setscrew (3); install setscrew and tighten.

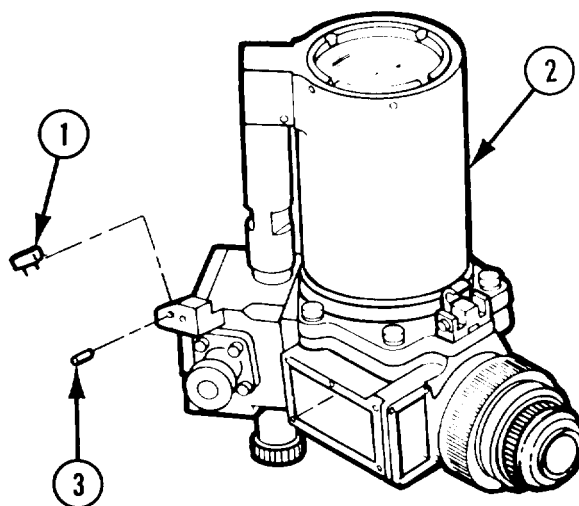

- 3 Install gasket (4).
- 4 Attach six wires to switch assembly (5) using solder.
- 5 Install switch assembly (5) on elbow assembly (2) and secure with four lockwashers (6) and four machine screws (7).
- 6 Fill two small holes (8) in switch assembly cover plate with white silicone adhesive.

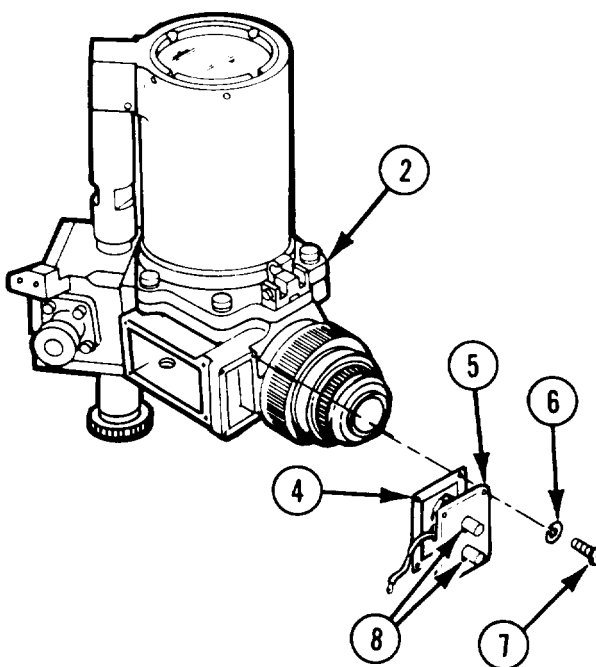

3-7. SWITCH ASSEMBLY – MAINTENANCE INSTRUCTIONS. (cont)

DISASSEMBLY

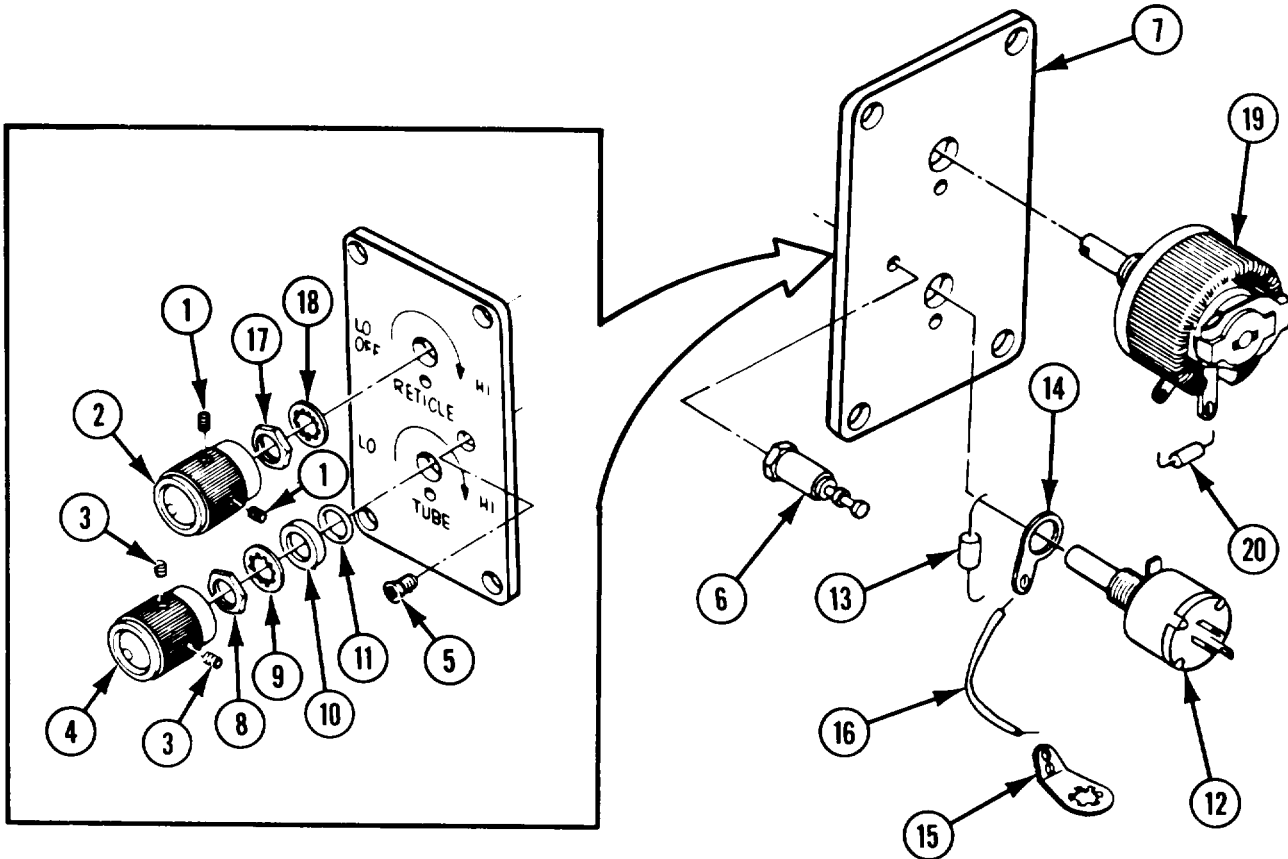

- 1 Loosen two setscrews (1) and remove RETICLE control knob (2).
- 2 Loosen two setscrews (3) and remove TUBE control knob (4).
- 3 Remove machine screw (5) and stud terminal (6) from plate (7).
- 4 Remove nut (8), lockwasher (9), spacer (10), and packing (11); pull out TUBE variable resistor (12).
- 5 Unsolder fixed resistor (13) from terminal lug (14) and TUBE variable resistor (12).
- 6 Remove ground strap from TUBE variable resistor (12) and unsolder terminal lugs (14) and (15) from wire (16).
- 7 Remove nut (17) and lockwasher (18); pull out RETICLE variable resistor (19).
- 8 Unsolder wires from fixed resistor (20) and stud terminal (6) to RETICLE variable resistor (19).

INSPECTION/REPAIR

Replace any damaged, missing, or broken parts. See TM 9-1240-379-34P.

REASSEMBLY

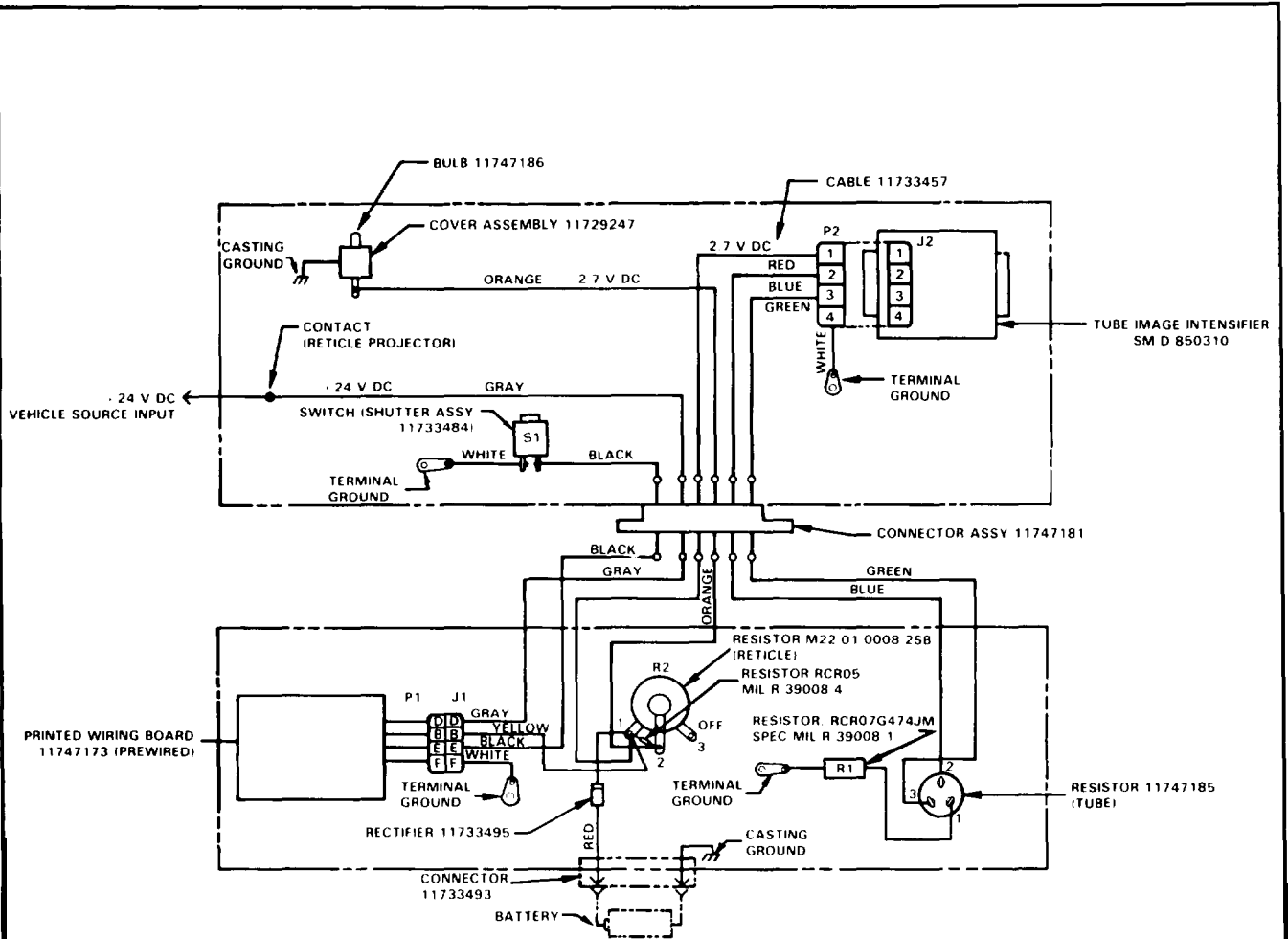

Wiring Diagram for Switch Assembly

NOTE

Refer to wiring diagram as needed during reassembly

3-7. SWITCH ASSEMBLY—MAINTENANCE INSTRUCTIONS. (cont)

REASSEMBLY

- 1 Fabricate replacement electrical wire (fig. C-3, app C).
- 2 Attach fixed resistor (1) to stud terminal (2) and RETICLE variable resistor (3) using solder.
- 3 Secure RETICLE variable resistor (3) to plate (4) with lockwasher (5) and nut (6).
- 4 Attach terminal lugs (7) and (8) to wire (9) using solder.
- 5 Install ground strap on TUBE variable resistor (10).
- 6 Attach fixed resistor (11) to terminal lug (7) and TUBE variable resistor (10) using solder.
- 7 Secure TUBE variable resistor (10) to plate (4) with packing (12), spacer (13), lockwasher (14), and nut (15).
- 8 Install stud terminal (2) and machine screw (16).
- 9 Install TUBE control knob (17) and tighten two setscrews (18).
- 10 Install RETICLE control knob (19) and tighten two setscrews (20).
- 11 After maintenance has been completed, purge and charge in accordance with TM 750-116.

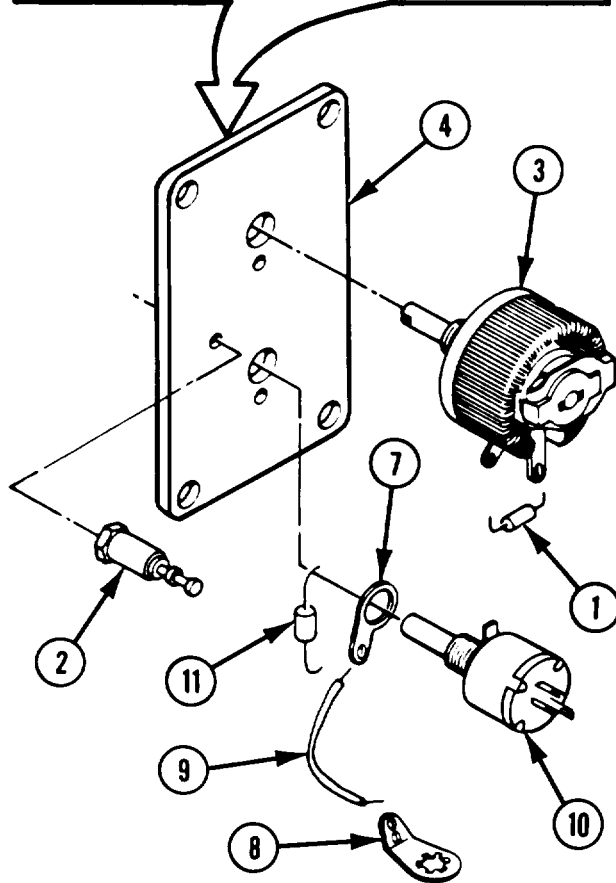
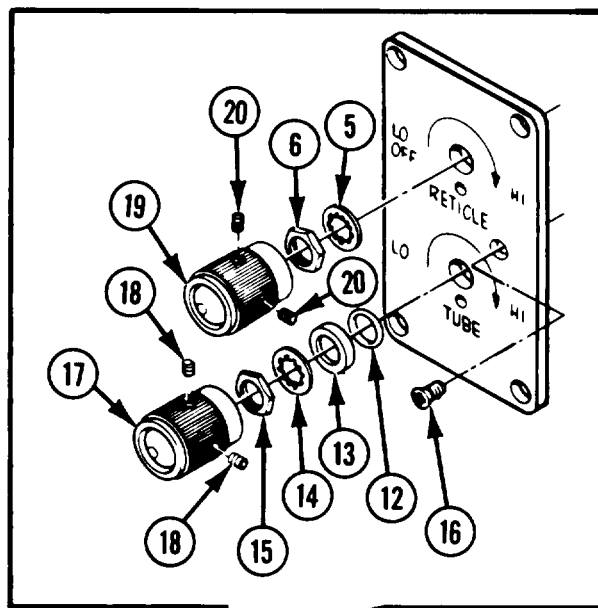

Section III. FINAL INSPECTION

3-8. SCOPE.

Final inspection of the tank periscope is done after repair has been completed to be sure that it is serviceable according to established standards.

3-9. PURPOSE.

Satisfactory completion of final inspection

steps will certify the tank periscope as completely serviceable for return to the user.

3-10. INSPECTION OF TANK PERISCOPE.

a. Completeness. The tank periscope must be complete with all necessary attaching hardware in place and secured.

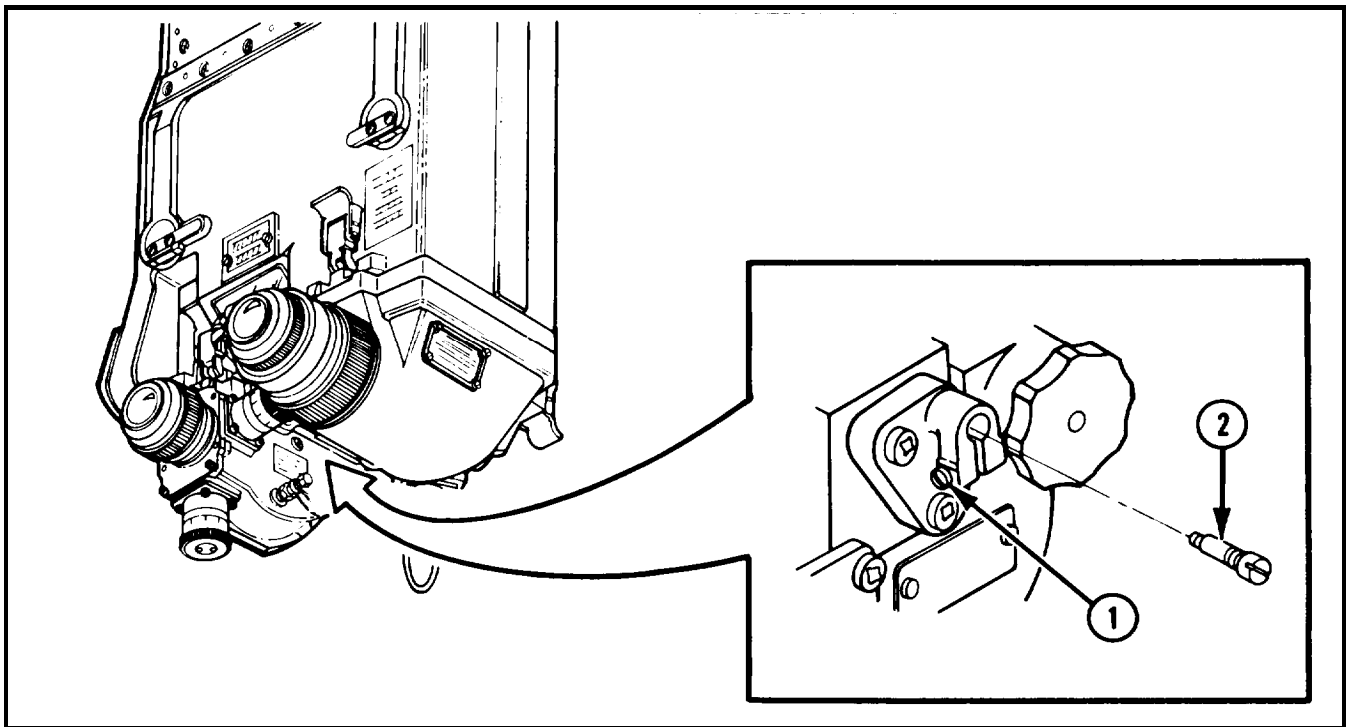

b. Parallax (Elbow Assembly, Infrared Body Assembly, and Daylight Body Assembly). Look at a target at 1200 meters (3937 feet) through the daylight body assembly. Parallax should not exceed the thickness of one reticle line. If parallax exceeds the thickness of one reticle line, loosen screw (1) and rotate eccentric (2) until reticle line is superimposed on the target. Tighten screw (1).

c. Focus (Elbow Assembly, Infrared Body Assembly, and Daylight Body Assembly).

(1) Elbow assembly and infrared body assembly. Viewing through a dioptometer, rotate the diopter ring to bring the phosphor grain of the face of the image intensifier into best focus. The diopter scale should index at zero within plus or minus 1/4 diopter.

NOTE

If parallax still exceeds the thickness of one reticle line, return to depot.

3-10. INSPECTION OF TANK PERISCOPE. (cont)

(2) Daylight body assembly. Viewing through a dioptrimeter, rotate the diopter ring to bring the daylight body reticle into best focus. The diopter scale should index zero plus or minus 1/4 diopter.

NOTE

Attempt to position the tank periscope on as level a plane as conditions permit. Deviation from this level plane will affect the mil value obtained. This check will normally suffice for determining parallelism of the reticle and image.

d. Parallelism of Reticle and Image. Look through the daylight body assembly at a target with sharp horizontal and vertical lines such as a building at a distance of 1200 meters (3937 feet). The lines on the target should be parallel with the lines on the reticle image in the daylight body assembly within two mils of arc. Repeat this check looking through eyepiece of the elbow assembly.

NOTE

Steps e thru g below pertain to the elbow assembly only.

e. Shutter Assembly Switch. Connect tank periscope to a 24 V dc power source

and at light conditions that simulate dawn or dusk, turn shutter assembly switch ON. Look into the eyepiece and make sure that an image is visible. If needed, rotate TUBE control knob clockwise from LO to HI until an image appears.

f. TUBE Control Knob. With tank periscope connected to a power source and the shutter assembly switch ON, rotate TUBE control knob clockwise throughout its range from LO to HI while observing image through the eyepiece. Be sure that the light level increases and decreases as the TUBE control knob is turned clockwise and counterclockwise, respectively.

g. RETICLE Control Knob. With tank periscope connected to a power source and the shutter assembly switch ON, rotate the RETICLE control knob clockwise from OFF and LO to HI. The image of the reticle should appear as you look into the eyepiece. The image should grow brighter as you rotate the RETICLE control knob towards HI, become dimmer as you return to LO, and disappear when you turn it OFF.

h. Electrical Operation. Make sure that all electrical systems function properly and that the electrical system of the infrared body assembly operates properly in both modes.

APPENDIX A REFERENCES

A-1. TECHNICAL MANUALS.

TM 9-254	General Maintenance Procedures for Fire Control Materiel
TM 9-258	Elementary Optics and Application to Fire Control Instruments
TM 9-1240-379-34P	Direct Support and General Support Maintenance Repair Parts and Special Tools List (Including Depot Maintenance Repair Parts) For Tank Periscope: M32 (1240-00-766-4287), M32C (1240-00-762-9335), M32E1 (1240-00-016-2272), M32CE1 (1240-00-092-7910)
TM 9-2350-215-10-1	Operator's Manual: Operator's Controls and PMCS for Tank, Combat, Full-Tracked: 105-MM Gun, M60A1
TM 9-2350-257-10-1	Operator's Manual for Tank, Combat, Full-Tracked: 105-MM Gun, M60A1 (Rise) and M60A1 (Rise Passive)
TM 9-2350-258-10	Operator's Manual for Tank, Combat, Full-Tracked, 105-MM Gun, M48A5
TM 9-2350-260-10-1	Operator's Manual: Operator's Controls and PMCS for Tank, Combat, Full-Tracked: 105-MM Gun, M60
TM 750-116.	General Procedures for Purging and Charging of Fire Control Instruments
TM 750-244-6	Procedures for Destruction of Tank-Automotive Equipment to Prevent Enemy Use
TM 4700-15/1	Marine Corps Equipment Record Procedures

A-2. SUPPLY CATALOGS.

SC 4931-95-CL-A07	Shop Equipment, Instrument and Fire Control: Field Maintenance, Basic, Less Power
SC 4931-95-CL-A09	Shop Equipment, Instrument and Fire Control System Repair: Field Maintenance

A-2. SUPPLY CATALOGS. (cont)

SC 4931-95-CL-J52 Fire Control Maintenance and Repair Shop
Specialized Equipment Wrench Set, Spanner,
DS, GS, and Depot Maintenance: Tube Double-
End Concave Inserted Blade, Set of 76
Wrenches

A-3. BLANK FORMS.

DA 2028 Recommended Changes to Publications and
Blank Forms

DA 2028-2 Recommended Changes to Equipment Technical
Publications

MCO 4855.10 Quality Deficiency Report

NAVMC 10772 Recommended Changes to Navy and Marine
Corps Equipment/Technical Publications

SF 368 Quality Deficiency Report
(Category II)

A-4. MISCELLANEOUS PUBLICATIONS.

CTA 8-100 Army Medical Department Expendable/Durable
Items

CTA 50-970 Expendable/Durable Items (Except: Medical,
Class V, Repair Parts and Heraldic Items)

DA PAM 738-750 The Army Maintenance Management System
(TAMMS)

FM 21-11 First Aid for Soldiers

MIL-P-116 Methods of Preservation

APPENDIX B

EXPENDABLE/DURABLE SUPPLIES AND MATERIALS LIST

Section I. INTRODUCTION

B-1. SCOPE.

This appendix lists expendable/durable supplies and materials you will need to operate and maintain the tank periscope. This listing is for informational purposes only and is not authority to requisition the listed item. These items are authorized to you by CTA 50-970, Expendable/Durable Items (Except Medical, Class V, Repair Parts, and Heraldic Items), or CTA 8-100, Army Medical Department Expendable/Durable Items.

B-2. EXPLANATION OF COLUMNS.

a. Column (1)—Item Number. This number is assigned to the entry in the listing and is referenced in the narrative instructions to identify the material (e.g., “Use cleaning compound, item 5, app B.”).

b. Column (2)—Level. This column identifies the lowest level of maintenance that requires the listed item.

F—Direct Support Maintenance
H—General Support Maintenance

c. Column (3)—National Stock Number. This is the National stock number assigned to the item; use it to request or requisition the item.

d. Column (4)—Description. Indicates the Federal item name and, if required, a description to identify the item. The last line for each item indicates the Federal Supply Code for Manufacturer (FSCM) in parentheses followed by the part number.

e. Column (5)—Unit of Measure (U/M). Indicates the measure used in performing the actual maintenance function. This measure is expressed by a two-character alphabetical abbreviation (e.g., ea, in., pr). If the unit of measure differs from the unit of issue, requisition the lowest unit of issue that will satisfy your requirements.

Section II. EXPENDABLE/DURABLE SUPPLIES AND MATERIALS LIST

(1) ITEM NUMBER	(2) LEVEL	(3) NATIONAL STOCK NUMBER	(4) DESCRIPTION	(5) U/M
1	H	8040-00-225-4548	ADHESIVE, silicone, white (81349) MIL-A-46106	OZ
2	F	8105-00-269-4662	BAG, PLASTIC (81349) MIL-B-117	EA
3	F	8020-00-244-0153	BRUSH, ARTIST'S (81348) H-B-241	EA
4	F	8115-00-995-2757	BOX, SHIPPING (81348) PPPB636	EA
5	F	...	CAP, PROTECTIVE (81349) MIL-C-5501	EA
6	F	5350-00-221-0872	CLOTH, ABRASIVE, CROCUS (81348) P-C-458	SH
7	F	8135-00-989-9888	CUSHIONING MATERIAL (81348) PPPC1120	YD
8	F	6850-00-281-1985	DRY CLEANING SOLVENT (81348) P-D-680	GL
9	F	6810-00-264-6507	ETHYL ALCOHOL, ACS (81349) O-E-00760	GL
10	F	8415-00-823-7457	GLOVES, CHEMICAL AND SOLVENT RESISTANT (81348) ZZ-G-381	PR
11	F	9150-00-269-8255	GREASE, AIRCRAFT (81349) MIL-G-4343	LB
12	F	6830-00-782-2641	NITROGEN, TECHNICAL (81348) BBN411	TK
13	F	8135-00-242-5610	PAPERBOARD, WRAPPING AND CUSHIONING (81348) PPP-P-291	RO
14	F	6640-00-436-5000	PAPER, LENS (81348) NNNP40	SH

(1) ITEM NUMBER	(2) LEVEL	(3) NATIONAL STOCK NUMBER	(4) DESCRIPTION	(5) U/M
15	F	8135-00-664-0028	PAPER, WRAPPING, LAMINATED AND CREPED (81349) MIL-P-130	RO
16	F	8030-00-252-3391	SEALING COMPOUND (81349) MIL-S-45180	OZ
17	F	8135-00-239-5311	SEAL, STRAPPING (81348) QQS781	EA
18	F	3439-00-453-5472	SOLDER, TIN ALLOY (81348) QQ-S-571	RO
19	F	8135-00-292-2351	TAG, SHIPPING (81348) UU-T-81	EA
20	F	7150-00-266-6716	TAPE, PRESSURE SENSITIVE (81348) PPP-T-97	IN.
21	F	7510-00-053-0942	TAPE, PRESSURE SENSITIVE ADHESIVE (81348) PPPT76	IN.
22	F	8110-00-271-1510	TUBE, MAILING (81348) PPP-T-495	EA

APPENDIX C

ILLUSTRATED LIST OF MANUFACTURED ITEMS

C-1. INTRODUCTION.

a. This appendix includes complete instructions for making items authorized to be manufactured or fabricated at general support maintenance.

b. A part number index in alphanumeric order is provided for cross-referencing the part number of the item to be manufactured to the figure which covers fabrication criteria.

c. All bulk materials needed for manufacture of an item are listed by part number or

specification number in a tabular list on the illustration.

Part Number	Figure
M16878/1BFE9	C-3
M16878/4BFE0	C-5
M16878/4BGE9	C-1
M23053/5-104-9	C-2
M7444-1-1-16	C-2
10556096	C-4

C-2. FABRICATION INSTRUCTIONS.

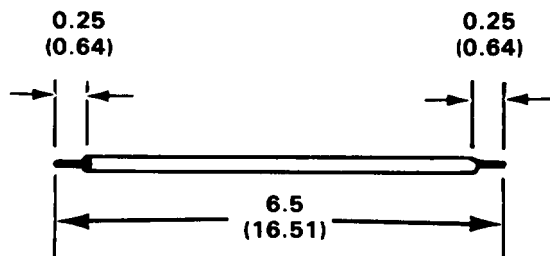

All dimensions shown are in inches with the metric conversion to centimeters in parentheses.

Figure C-1. Insulated Wire (Part No. M16878/4BGE9).

NOTES:

1. Required for daylight body assembly.
2. Fabricate from NSN 6145-01-110-8905.
3. Material: wire, insulated.
4. Strip insulation from both wire ends as illustrated.
5. Tin wire ends with solder (item 18, app B).

C-2. FABRICATION INSTRUCTIONS. (cont)

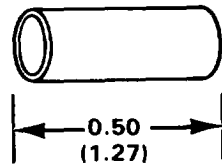

All dimensions shown are in inches with the metric conversion to centimeters in parentheses.

Figure C-2. Insulation Sleeve (Part No. M7444-1-1-16 or M23053/5-104-9).

NOTES:

1. Required for infrared body assembly.
2. Fabricate from NSN 5970-00-833-9166 or 5970-00-088-2975.
3. Material: sleeving, insulation.

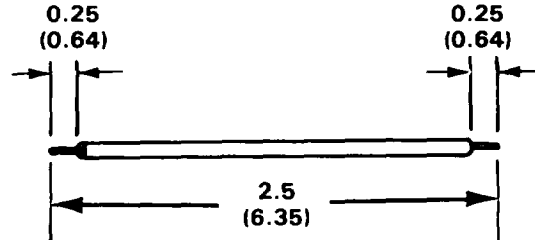

All dimensions shown are in inches with the metric conversion to centimeters in parentheses.

Figure C-3. Insulated Wire (Part No. M16878/1BFE9).

NOTES:

1. Required for switch assembly.
2. Fabricate from NSN 6145-00-652-1784.
3. Material: wire, insulated.
4. Strip insulation from both wire ends as illustrated.
5. Tin wire ends with solder (item 18, app B).

C-2. FABRICATION INSTRUCTIONS. (cont)

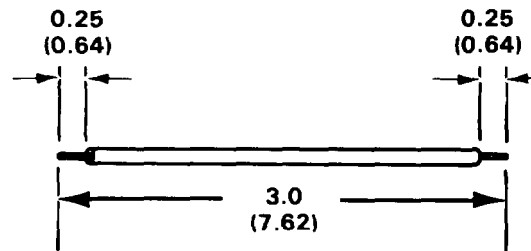

All dimensions shown are in inches with the metric conversion to centimeters in parentheses.

Figure C-5. Insulated Wire (Part No. M16878/4BFE0).

NOTES:

1. Required for infrared body assembly.
2. Fabricate from NSN 6145-00-062-6683.
3. Material: wire, insulated.
4. Strip insulation from both wire ends as illustrated.
5. Tin wire ends with solder (item 18, app B).

ALPHABETICAL INDEX

C

	DS*	GS**
Common tools and equipment	1-2	1-2

D

Daylight body assembly:		
Disassembly	2-16	3-5
Inspection/repair	2-20	3-6
Maintenance	2-16	3-5
Reassembly	2-20	3-6
Destruction of Army materiel to prevent enemy use	1-1	1-1
Differences between models	1-7	1-7

E

Elbow assembly:		
Disassembly	2-39	3-16
Inspection/cleaning/repair	2-41	
Inspection/repair		3-16
Maintenance	2-39	3-15
Reassembly	2-42	3-17
Equipment characteristics, capabilities, and features	1-3	1-3
Expendable supplies and materials list	B-1	B-1
Eyepiece assembly:		
Disassembly	2-48	
Inspection/cleaning/repair	2-48	
Maintenance	2-47	
Reassembly	2-48	

F

Final inspection		3-23
----------------------------	--	------

H

Head assembly:		
Disassembly	2-12	3-3
Inspection/cleaning/repair		3-4
Inspection/repair	2-13	
Maintenance	2-11	3-3
Reassembly	2-14	3-4

*Direct support maintenance

* *General support maintenance

	I	DS*	GS**
Illustrated list of manufactured items			C-1
Infrared body assembly:			
Disassembly		2-28	3-9
Inspection/repair		2-30	3-12
Maintenance		2-27	3-9
Reassembly.		2-31	3-13
Inspection of tank periscope			3-23
	L		
Location and description of major components		1-4	1-4
	M		
Maintenance forms, records, and reports		1-1	1-1
	O		
Official nomenclature, names, and designations		1-2	1-2
Operating principles		1-8	1-8
Optical cell assembly:			
Disassembly		2-37	3-7
Inspection/cleaning/repair.		2-38	3-8
Maintenance		2-37	3-7
Reassembly		2-38	3-8
	P		
Pre-embarkation inspection of materiel in units alerted for overseas movement		2-50	
Preparation for storage or shipment		2-49	
Prism cell:			
Disassembly		2-46	
Inspection/cleaning/repair.		2-46	
Maintenance		2-45	
Reassembly		2-47	

*Direct support maintenance
 **General support maintenance

	R	DS*	GS**
References		A-1	A-1
Repair parts		1-2	1-2
Reporting equipment improvement recommendations (EIR)		1-2	1-2
S			
Safety, care, and handling		1-8	1-8
Scope		1-1	1-1
Special tools, TMDE, and support equipment		1-2	1-2
Switch assembly:			
Disassembly			3-20
Inspection/repair			3-21
Maintenance			3-19
Reassembly			3-21
T			
Tank periscope:			
Disassembly		2-8	
Inspection/cleaning/repair.		2-9	
Maintenance		2-8	
Reassembly		2-10	
Troubleshooting information.		2-1	3-1

*Direct support maintenance
 * *General support maintenance

By Order of the Secretary of the Army:

CARL E. VUONO
General United States Army
Chief of Staff

Official:

R. L. DILWORTH
Brigadier General United States Army
The Adjutant General

DISTRIBUTION:

To be distributed in accordance with DA Form 12-41, Direct Support and General Support Maintenance requirements for Periscope, Tank, M32E1.

J. J. WENT
LT. GEN, U.S. Marine Corps
Deputy Chief of Staff for Installation and Logistics

DISTRIBUTION;
AA, AS, L82

RECOMMENDED CHANGES TO EQUIPMENT TECHNICAL PUBLICATIONS



THEN JOT DOWN THE DOPE ABOUT IT ON THIS FORM. CAREFULLY TEAR IT OUT, FOLD IT AND DROP IT IN THE MAIL.

SOMETHING WRONG WITH THIS PUBLICATION?

FROM (PRINT YOUR UNIT'S COMPLETE ADDRESS)

Your mailing address

DATE SENT Date you filled out this form

PUBLICATION NUMBER
 ARMY TM 9-1240-379-34
 MARINE CORPS TM 04332A-34

PUBLICATION DATE

PUBLICATION TITLE DS & GS Maintenance
 Manual for M32, M32C, M32E1, &
 M32CE1 Tank Periscope

BE EXACT PIN-POINT WHERE IT IS

PAGE NO	PARA GRAPH	FIGURE NO	TABLE NO
2-12	2-3		

IN THIS SPACE TELL WHAT IS WRONG AND WHAT SHOULD BE DONE ABOUT IT:

Callouts 3 and 4 should be reversed.

SAMPLE

PRINTED NAME, GRADE OR TITLE, AND TELEPHONE NUMBER

SIGN HERE

Your name

RECOMMENDED CHANGES TO EQUIPMENT TECHNICAL PUBLICATIONS



SOMETHING WRONG WITH THIS PUBLICATION?

FROM (PRINT YOUR UNIT'S COMPLETE ADDRESS)

DATE SENT

THEN JOT DOWN THE DOPE ABOUT IT ON THIS FORM. CAREFULLY TEAR IT OUT, FOLD IT AND DROP IT IN THE MAIL.

PUBLICATION NUMBER ARMY TM 9-1240-379-34 MARINE CORPS TM 04332A-34	PUBLICATION DATE 12 MAY 88	PUBLICATION TITLE DS & GS Maintenance Manual for M32, M32C, M32E1, & M32CE1 Tank Periscope
--	-------------------------------	---

BE EXACT PIN-POINT WHERE IT IS				IN THIS SPACE TELL WHAT IS WRONG AND WHAT SHOULD BE DONE ABOUT IT:
PAGE NO	PARA-GRAPH	FIGURE NO	TABLE NO	

PRINTED NAME GRADE OR TITLE AND TELEPHONE NUMBER	SIGN HERE
--	-----------

FILL IN YOUR
UNIT'S ADDRESS



FOLD BACK

DEPARTMENT OF THE ARMY



OFFICIAL BUSINESS
PENALTY FOR PRIVATE USE, \$300

NO POSTAGE
NECESSARY
IF MAILED
IN THE
UNITED STATES

TEAR ALONG PERFORATED LINE

BUSINESS REPLY MAIL

FIRST CLASS PERMIT NO 12062 WASHINGTON, DC

POSTAGE WILL BE PAID BY DEPARTMENT OF THE ARMY



Commander
US Army Armament, Munitions and Chemical Command
ATTN: AMSMC-MAS
Rock Island, IL 61201-9990

FILL IN YOUR
UNIT'S ADDRESS

FOLD BACK

DEPARTMENT OF THE ARMY



OFFICIAL BUSINESS
PENALTY FOR PRIVATE USE, \$300

NO POSTAGE
NECESSARY
IF MAILED
IN THE
UNITED STATES

BUSINESS REPLY MAIL

FIRST CLASS

PERMIT NO. 12062

WASHINGTON, DC

POSTAGE WILL BE PAID BY DEPARTMENT OF THE ARMY

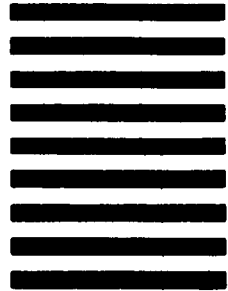

Commander
US Army Armament, Munitions and Chemical Command
ATTN: AMSMC-MAS
Rock Island, IL 61201-9990

TEAR ALONG PERFORATED LINE

RECOMMENDED CHANGES TO EQUIPMENT TECHNICAL PUBLICATIONS

 <p style="font-size: 1.2em; font-weight: bold; margin: 0;">SOMETHING WRONG WITH THIS PUBLICATION?</p>		FROM (PRINT YOUR UNIT'S COMPLETE ADDRESS)	
		DATE SENT	
PUBLICATION NUMBER ARMY TM 9-1240-379-34 MARINE CORPS TM 04332A-34	PUBLICATION DATE 12 MAY 88	PUBLICATION TITLE DS & GS Maintenance Manual for M32, M32C, M32E1, & M32CE1 Tank Periscope	
BE EXACT PIN-POINT WHERE IT IS		IN THIS SPACE TELL WHAT IS WRONG AND WHAT SHOULD BE DONE ABOUT IT:	
PAGE NO	PARA-GRAPH		FIGURE NO
PRINTED NAME GRADE OR TITLE AND TELEPHONE NUMBER		SIGN HERE	

DA FORM 2028-2
1 JUL 79

PREVIOUS EDITIONS ARE OBSOLETE

PS --IF YOUR OUTFIT WANTS TO KNOW ABOUT YOUR RECOMMENDATION MAKE A CARBON COPY OF THIS AND GIVE IT TO YOUR HEADQUARTERS

FILL IN YOUR
UNIT'S ADDRESS

FOLD BACK

DEPARTMENT OF THE ARMY



OFFICIAL BUSINESS
PENALTY FOR PRIVATE USE, \$300

NO POSTAGE
NECESSARY
IF MAILED
IN THE
UNITED STATES

BUSINESS REPLY MAIL

FIRST CLASS

PERMIT NO. 12062

WASHINGTON, DC

POSTAGE WILL BE PAID BY DEPARTMENT OF THE ARMY

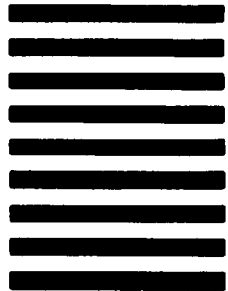

Commander
US Army Armament, Munitions and Chemical Command
ATTN: AMSMC-MAS
Rock Island, IL 61201-9990

TEAR ALONG PERFORATED LINE

